

# Makita®

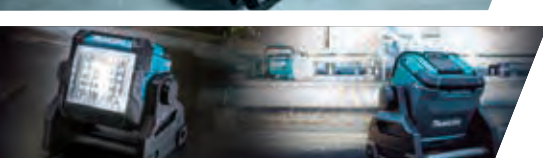

Catálogo accesorios  
**CONSTRUCCIÓN**  
2025

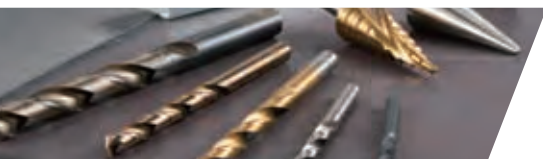

<b>1. Perforación y demolición</b>	<b>3-23</b>
<b>2. Taladrar</b>	<b>24-40</b>
<b>3. Atornillar</b>	<b>41-50</b>
<b>4. Limpiar y cepillar</b>	<b>51-52</b>
<b>5. Diamante</b>	<b>53-63</b>
<b>6. Amoladoras</b>	<b>64-68</b>
<b>7. Abrasivos</b>	<b>69-74</b>
<b>8. Multiherramienta</b>	<b>75-79</b>
<b>9. Sierras circulares, ingletadoras y de incisión</b>	<b>80-91</b>
<b>10. Sierras de sable</b>	<b>92-100</b>
<b>11. Sierras de calar</b>	<b>101-107</b>
<b>12. Niveles</b>	<b>108</b>
<b>13. Iluminación</b>	<b>109-111</b>





## Brocas T.C.T para martillos SDS-Plus

Producto	Standmak	V-Plus	SDS-V-Plus Mak 4	NEMESIS
Rango	★★	★★★★	★★★	★★★★★
Punta				
Tipo	Pastilla de 2 cortes	Pastilla de 2 cortes	Pastilla de 4 cortes	Pastilla sólida de 4 cortes
Espiral	Espiral doble estándar	Espiral doble de alta durabilidad	Espiral doble estándar	Espiral cuádruple de alta durabilidad
Tamaño	3,5 - 30mm	3,5 - 26mm	5 - 25mm	5 - 32mm
Equilibrio de propiedades	 A- Velocidad B- Vida útil C- Fácil posicionamiento D- Precisión E- Anti-rotura de rebarba			
Material de trabajo				

La pastilla sólida de 4 cortes sólo está disponible hasta brocas de 16mm Ø

## Brocas T.C.T para martillos SDS-Max



Producto	Standard	Mak 4
Rango	★★	★★★
Punta		
Tipo	Pastilla de 2 cortes	Pastilla de 4 cortes
Espiral	Espiral doble estándar	Espiral doble estándar
Tamaño	12 - 40mm	12-30mm
Equilibrio de propiedades	 A- Velocidad B- Vida útil C- Fácil posicionamiento D- Precisión E- Anti-rotura de rebarba	
Material de trabajo		



Brocas SDS-PLUS **NEMESIS II**

**La espiral**

**4CORTES**

**Resuelve problemas**

Nota: Cuando encontramos varillas en el hormigón no hay que apretar. Dejar que la broca vaya cortando con una ligera presión.

Su diseño en espiral de cuatro salidas asegura que la carga de perforación se distribuya uniformemente a lo largo del eje de la broca. El acero de alta calidad y el tratamiento especial de la superficie garantizan la resistencia de la broca.



4 x 90°, la broca corta de manera uniforme el metal y no se bloquea con las varillas de acero reforzado.



Núcleo de la espiral mejorado. Garantiza bajas vibraciones y una excepcional resistencia a la rotura.



La punta de centrado facilita la perforación del material con una precisión milimétrica.



El diseño simétrico de las 4 espirales aseguran que el desgaste sea bajo y uniforme.



La amplia geometría de las espirales permite un óptimo transporte del polvo del taladro.

**Brocas de 5 a 16mm.**



Ø (mm)	Largo (mm)	Long. útil (mm)	Uds.	Código	EAN	P.V.P. (€)
5	115	50	1	B-57897	0088381520782	5,30
5	165	100	1	B-57906	0088381520799	5,60
5	215	150	1	B-57912	0088381520805	8,60
5	265	200	1	B-57928	0088381520812	8,90
5,5	115	50	1	B-57940	0088381520836	5,30
5,5	165	100	1	B-57956	0088381520843	5,60
6	115	50	1	B-57962	0088381520850	5,30
6	165	100	1	B-57978	0088381520867	5,60
6	215	150	1	B-57984	0088381520874	7,20
6	265	200	1	B-57990	0088381520881	8,60
6	315	250	1	B-58001	0088381520898	11,90
6,5	165	100	1	B-58023	0088381520911	7,50
6,5	215	150	1	B-58039	0088381520928	9,70
6,5	265	200	1	B-58045	0088381520935	12,20
6,5	315	250	1	B-58051	0088381520942	14,80
7	115	50	1	B-58067	0088381520959	6,70
7	165	100	1	B-58073	0088381520966	7,50
7	215	150	1	B-58089	0088381520973	10,90
8	115	50	1	B-58095	0088381520980	6,10
8	165	100	1	B-58104	0088381520997	6,40
8	215	150	1	B-58110	0088381521000	7,50
8	265	200	1	B-58126	0088381521017	8,90
8	315	250	1	B-58132	0088381521024	12,20
8	465	400	1	B-58154	0088381521048	19,50
9	165	100	1	B-58176	0088381521062	7,00
10	115	50	1	B-58198	0088381521086	6,40
10	165	100	1	B-58207	0088381521093	7,20
10	215	150	1	B-58213	0088381521109	8,10
10	265	200	1	B-58229	0088381521116	9,50
10	315	250	1	B-58235	0088381521123	12,30
10	455	390	1	B-58257	0088381521147	21,00
10	600	540	1	B-58263	0088381521154	28,00
10	1000	940	1	B-58279	0088381521161	67,00
11	160	100	1	E-14495	0088381594097	8,20
11	210	160	1	E-14504	0088381594103	9,90
11	260	210	1	E-14510	0088381594110	11,60
11	310	260	1	E-14526	0088381594127	16,00
12	160	110	1	E-14532	0088381594134	7,70

**Brocas de 18 a 32mm.**



Ø (mm)	Largo (mm)	Long. útil (mm)	Uds.	Código	EAN	P.V.P. (€)
12	210	160	1	E-14548	0088381594141	9,40
12	260	210	1	E-14554	0088381594158	10,50
12	310	260	1	E-14560	0088381594165	14,90
12	450	400	1	E-14576	0088381594172	22,00
12	600	550	1	E-14582	0088381594189	28,00
12	1000	950	1	E-19598	0088381786669	67,00
14	160	110	1	E-14635	0088381594233	11,00
14	210	160	1	E-14641	0088381594240	14,90
14	260	210	1	E-14657	0088381594257	17,10
14	310	260	1	E-14663	0088381594264	18,20
14	450	400	1	E-14679	0088381594271	24,00
14	600	550	1	E-14685	0088381594288	31,00
14	1000	950	1	E-19607	0088381786676	70,00
15	160	110	1	E-14691	0088381594295	17,10
15	210	160	1	E-14700	0088381594301	19,30
15	260	210	1	E-14716	0088381594318	21,00
15	450	400	1	E-14722	0088381594325	28,00
16	160	110	1	E-14738	0088381594332	17,70
16	210	160	1	E-14744	0088381594349	20,00
16	260	210	1	E-14750	0088381594356	22,00
16	310	260	1	E-14766	0088381594363	25,00
16	450	400	1	E-14772	0088381594370	31,00
16	600	550	1	E-14788	0088381594387	39,00
16	1000	950	1	E-19613	0088381786683	80,00
18	250	200	1	B-58615	0088381521505	29,00
18	450	400	1	B-58621	0088381521512	33,00
20	250	200	1	B-58637	0088381521529	32,00
20	450	400	1	B-58659	0088381521543	39,00
22	250	200	1	B-58665	0088381521550	36,00
22	450	400	1	B-58687	0088381521574	48,00
24	250	200	1	B-58693	0088381521581	46,00
24	450	400	1	B-58702	0088381521598	52,00
25	250	200	1	B-58718	0088381521604	46,00
25	450	400	1	B-58724	0088381521611	58,00
28	250	200	1	B-58746	0088381521635	52,00
28	450	400	1	B-58752	0088381521642	67,00
30	250	200	1	B-58768	0088381521659	59,00
30	450	400	1	B-58774	0088381521666	74,00
32	450	400	1	B-58780	0088381521673	95,00

\* A partir de 18mm las brocas son de 3 piezas de carburo.



**Gama de brocas SDS-V-PLUS MAK4.**

**Para martillos SDS-PLUS. Brocas con cabeza de 4 puntas.**

**Puede taladrar en hormigón armado. Taladros más PRECISOS que con las brocas de 2 puntas.**

**Indicado para todo tipo de trabajos donde se utiliza martillos ligeros SDS-PLUS.**



**Estuches de brocas Némesis (10 uds)**



Ø (mm)	Largo (mm)	Long. útil (mm)	Uds.	Código	EAN	P.V.P. (€)
5	115	50	10	B-63214	0088381532426	48,00
5	165	100	10	B-63220	0088381532433	52,00
6	115	50	10	B-63258	0088381532464	48,00
6	165	100	10	B-63264	0088381532471	52,00
8	115	50	10	B-63367	0088381532570	57,00
8	165	100	10	B-63373	0088381532587	60,00
10	115	50	10	B-63404	0088381532617	61,00
10	165	100	10	B-63410	0088381532624	67,00



**Brocas de 5 a 25mm.**



Ø (mm)	Largo (mm)	Long. útil (mm)	Uds.	Código	EAN	P.V.P. (€)
5	110	50	1	B-68127	0088381544696	2,80
5	160	100	1	B-68133	0088381544702	2,80
6	110	50	1	B-62496	0088381529938	3,40
6	160	100	1	B-62505	0088381529945	3,40
6	210	150	1	B-62511	0088381529952	4,00
6	260	200	1	B-62527	0088381529969	4,30
8	110	50	1	B-62608	0088381530040	4,10
8	160	100	1	B-62614	0088381530057	4,10
8	210	150	1	B-62620	0088381530064	4,70
8	260	200	1	B-62636	0088381530071	5,20
8	310	250	1	B-62642	0088381530088	5,60
10	110	50	1	B-62664	0088381530101	5,50
10	160	100	1	B-62670	0088381530118	5,50
10	210	150	1	B-62686	0088381530125	6,00
10	260	200	1	B-62692	0088381530132	6,60
10	310	250	1	B-62701	0088381530149	6,90
12	160	100	1	B-62739	0088381530170	7,40
12	210	150	1	B-62745	0088381530187	8,00
12	260	200	1	B-62751	0088381530194	8,60
12	310	250	1	B-62767	0088381530200	8,80
12	350	290	1	B-62773	0088381530217	9,90
14	160	100	1	B-62795	0088381530231	11,00
14	210	150	1	B-62804	0088381530248	11,60
14	260	200	1	B-62810	0088381530255	12,10
14	310	250	1	B-62826	0088381530262	12,40
14	350	290	1	B-62832	0088381530279	12,70
16	160	100	1	B-62854	0088381530293	13,20
16	210	150	1	B-62860	0088381530309	13,80
16	260	200	1	B-62876	0088381530316	14,40
16	310	250	1	B-62882	0088381530323	15,70
16	350	290	1	B-62898	0088381530330	16,30
18	260	200	1	B-68177	0088381544740	21,00
18	460	400	1	B-68236	0088381544801	26,00
20	260	200	1	B-68183	0088381544757	27,00
20	460	400	1	B-68242	0088381544818	31,00
22	260	200	1	B-68199	0088381544764	33,00
22	460	400	1	B-68258	0088381544825	41,00
25	260	200	1	B-68208	0088381544771	42,00
25	460	400	1	B-68264	0088381544832	45,00



• **Potencia de rotura.**

Efecto demolición.  
Produce microrroturas en el taladrado.  
Genera mayor velocidad de taladrado.

• **Reduce la fricción en los laterales para aumentar la velocidad.**



• **Duración en hormigón armado.**

Mayor duración (+35%).  
Previene daños en la pastilla cuando golpea en varilla.  
Reduce la probabilidad de enganche durante el taladrado.

• **Flauta KVS.**

Geometría cónica de la flauta.  
De este modo ofrece gran velocidad y resistencia a la rotura.

• **Pastilla de centrado.**

• **Gran durabilidad.**

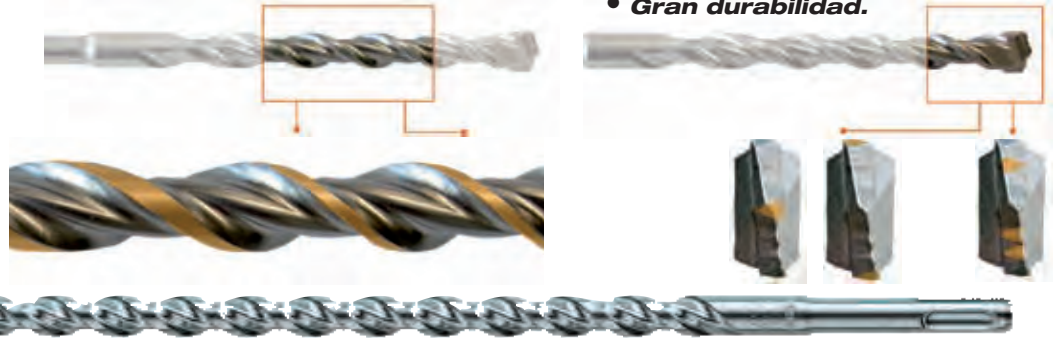

Ø (mm)	Largo (mm)	Long. útil (mm)	Uds.	Código	EAN	P.V.P. (€)
3,5	110	50	1	E-10665	0088381580434	6,10
4	110	50	1	B-47232	0088381454315	3,40
4	160	100	1	B-47248	0088381454322	3,90
4,5	160	100	1	E-10671	0088381580441	6,10
5	110	50	1	B-46492	0088381452427	2,80
5	160	100	1	B-46501	0088381452434	3,05
5,5	160	100	1	B-47307	0088381454384	3,60
5,5	210	150	1	B-47313	0088381454391	6,40
6	110	50	1	B-46517	0088381452441	2,80
6	160	100	1	B-46523	0088381452458	2,80
6	210	150	1	B-47341	0088381454421	4,20
6	260	200	1	B-47357	0088381454438	5,30
6,5	110	50	1	B-47385	0088381454469	3,05
6,5	160	100	1	B-47391	0088381454476	3,60
6,5	210	150	1	B-47400	0088381454483	4,70
6,5	260	200	1	B-47416	0088381454490	6,40
7	110	50	1	B-47438	0088381454513	3,05
7	160	100	1	B-47444	0088381454520	3,40
7	210	150	1	B-47450	0088381454537	5,00
8	110	50	1	B-46539	0088381452465	3,05
8	160	100	1	B-46545	0088381452472	3,40
8	210	150	1	B-47472	0088381454551	4,40
8	260	200	1	B-47488	0088381454568	5,60
8	400	340	1	B-47503	0088381454582	10,50
8	600	540	1	B-47525	0088381454605	15,60
9	160	100	1	B-47531	0088381454612	4,20
9	210	150	1	B-47547	0088381454629	5,60
9,5	160	100	1	B-47553	0088381454636	4,70
10	110	50	1	B-46551	0088381452489	3,60
10	160	100	1	B-46567	0088381452496	3,90
10	210	150	1	B-47569	0088381454643	5,20
10	260	200	1	B-47575	0088381454650	6,10
10	310	250	1	B-47581	0088381454667	7,00
10	450	390	1	B-47606	0088381454681	11,70
10	600	540	1	B-47612	0088381454698	16,10

Ø (mm)	Largo (mm)	Long. útil (mm)	Uds.	Código	EAN	P.V.P. (€)
10	1000	940	1	B-47634	0088381454711	41,00
11	160	110	1	B-47640	0088381454728	5,80
11	210	160	1	B-47656	0088381454735	6,40
11	260	210	1	B-47662	0088381454742	7,80
12	160	110	1	B-46573	0088381452502	4,70
12	210	160	1	B-47684	0088381454766	5,80
12	260	210	1	B-47690	0088381454773	7,20
12	310	260	1	B-47709	0088381454780	9,20
12	450	400	1	B-47721	0088381454803	12,80
12	600	550	1	B-47737	0088381454810	16,70
12	1000	950	1	B-47759	0088381454834	44,00
13	160	110	1	B-47765	0088381454841	5,80
13	210	160	1	B-47771	0088381454858	6,70
13	260	210	1	B-47787	0088381454865	7,80
13	310	260	1	B-47793	0088381454872	10,00
14	160	110	1	B-46589	0088381452519	6,40
14	210	160	1	B-47802	0088381454889	7,20
14	260	210	1	B-47818	0088381454896	8,90
14	310	260	1	B-47824	0088381454902	10,00
14	450	400	1	B-47830	0088381454919	15,60
14	600	550	1	B-47846	0088381454926	18,40
14	1000	950	1	B-47852	0088381454933	45,00
15	160	110	1	B-47868	0088381454940	8,10
15	210	160	1	B-47874	0088381454957	9,40
15	260	210	1	B-47880	0088381454964	10,30
15	450	400	1	B-47896	0088381454971	16,20
16	160	110	1	B-47905	0088381454988	7,80
16	210	160	1	B-47911	0088381454995	9,50
16	310	260	1	B-47933	0088381455015	12,30
16	450	400	1	B-47949	0088381455022	18,40
16	600	550	1	B-47955	0088381455039	22,00
16	800	750	1	B-47961	0088381455046	33,00
16	1000	950	1	B-47977	0088381455053	51,00
17	210	160	1	B-47983	0088381455060	14,40

**Brocas StandMak para martillos SDS-PLUS**



Ø (mm)	Largo (mm)	Long. útil (mm)	Uds.	Código	EAN	P.V.P. (€)
3,5	110	50	1	D-15665	0088381170079	1,25
4	110	50	1	D-00016	0088381169004	1,30
5	110	50	1	D-00022	0088381169011	1,30
5	160	100	1	D-00038	0088381169028	1,30
5,5	110	50	1	D-00044	0088381169035	1,30
5,5	160	100	1	D-16106	0088381187381	1,30
6	110	50	1	D-00050	0088381169042	1,30
6	160	100	1	D-00066	0088381169059	1,30
6	210	150	1	D-00072	0088381169066	1,60
6,5	110	50	1	D-00088	0088381169073	1,30
6,5	160	100	1	D-00094	0088381169080	1,30
7	110	50	1	D-00103	0088381169097	1,30
7	160	100	1	D-00119	0088381169103	1,30
8	110	50	1	D-00125	0088381169110	1,30
8	160	100	1	D-00131	0088381169127	1,35
8	210	150	1	D-00147	0088381169134	1,70
8	260	200	1	D-00153	0088381169141	2,00
9	160	100	1	D-08056	0088381182379	1,60
9	210	150	1	D-00169	0088381169158	1,70
9,5	210	150	1	D-03274	0088381173520	1,70
10	160	100	1	D-00175	0088381169165	1,60
10	210	150	1	D-00181	0088381169172	1,95
10	260	200	1	D-00197	0088381169189	1,95
10	310	250	1	D-00206	0088381169196	2,55
10	460	400	1	D-17538	0088381196574	4,80
12	160	100	1	D-00228	0088381169219	1,60
12	210	150	1	D-00234	0088381169226	1,95
12	260	200	1	D-00240	0088381169233	1,95
12	460	400	1	D-16271	0088381187558	4,90
13	160	100	1	D-00256	0088381169240	1,85
13	350	290	1	D-16128	0088381187404	2,95
14	160	100	1	D-00262	0088381169257	2,30
14	260	200	1	D-00278	0088381169264	2,60
14	460	400	1	D-17544	0088381196581	5,20
16	210	150	1	D-00290	0088381169288	3,70
16	310	250	1	D-00309	0088381169295	4,50
16	460	400	1	D-16287	0088381187565	6,20
18	210	150	1	D-00321	0088381169318	3,60
18	300	240	1	D-00337	0088381169325	5,20
18	460	400	1	D-17566	0088381196604	7,20
20	210	150	1	D-00359	0088381169349	4,50
20	310	250	1	D-00365	0088381169356	7,40
20	460	400	1	D-15235	0088381186339	7,90
22	260	200	1	D-00371	0088381169363	5,90

Ø (mm)	Largo (mm)	Long. útil (mm)	Uds.	Código	EAN	P.V.P. (€)
22	310	250	1	D-08062	0088381182386	7,10
22	460	400	1	D-15241	0088381186346	8,90
24	460	400	1	D-16302	0088381187589	9,70
25	260	200	1	D-00387	0088381169370	7,90
25	310	250	1	D-08517	0088381182454	9,10
25	460	400	1	D-15257	0088381186353	11,10
26	260	200	1	D-00393	0088381169387	10,50
26	460	400	1	D-15263	0088381186360	12,40
28	460	400	1	D-16318	0088381187596	17,60
30	460	400	1	D-17572	0088381196611	21,00

**Brocas StandMak para martillos SDS-PLUS**

• **Cajas de 25 unidades.**



\* Presentadas en caja de cartón. Brocas sueltas.

Ø (mm)	Largo (mm)	Long. útil (mm)	Uds.	Código	EAN	P.V.P. (€)
5	110	50	25	D-01155-25	0088381170598	26,00
6	110	50	25	D-01161-25	0088381170604	28,00
6	160	100	25	D-01177-25	0088381170611	30,00
8	160	100	25	D-01183-25	0088381170628	30,00
8	210	150	25	D-01199-25	0088381170635	38,80
10	160	100	25	D-01208-25	0088381170642	35,00
10	210	150	25	D-03707-25	0088381173995	42,00
12	160	100	25	D-03713-25	0088381174008	36,00
12	210	150	25	D-03729-25	0088381174015	43,00

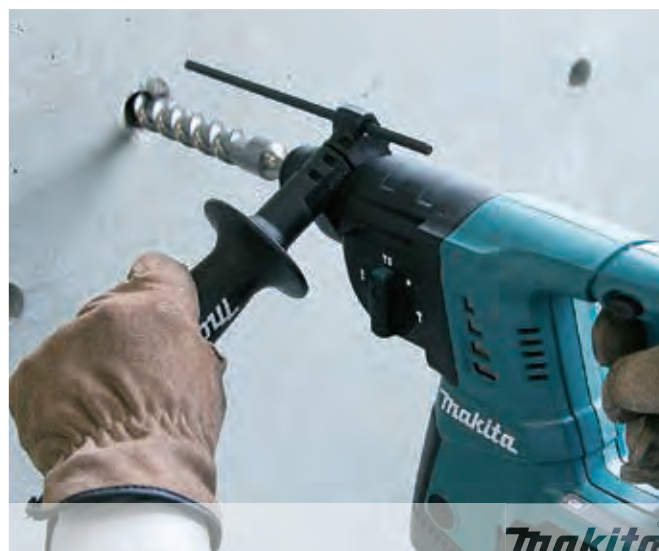



**Estuches y maletines de brocas**

**SDS-PLUS Némesis (7 piezas)**



**NEMESIS II**



Ø (mm)	Largo (mm)	Long. útil (mm)	Uds.	Código	EAN	P.V.P. (€)
5	110	50	1	E-14928	0088381594523	51,00
6	110	50	1			
8	110	50	1			
6	160	100	1			
8	160	100	1			
10	160	100	1			
12	160	100	1			



**SDS-PLUS Némesis (3 piezas)**



**NEMESIS II**



Ø (mm)	Largo (mm)	Long. útil (mm)	Uds.	Código	EAN	P.V.P. (€)
6	160	100	1	B-59075	0088381521963	21,00
8	160	100	1			
10	160	100	1			

**SDS-V-PLUS (13 piezas)**



**MAK 4**



Ø (mm)	Largo (mm)	Long. útil (mm)	Uds.	Código	EAN	P.V.P. (€)
6	110	50	1	B-64674	0088381535762	94,00
6	160	100	1			
7	110	50	1			
7	160	100	1			
8	110	50	1			
8	160	100	1			
10	110	50	1			
10	160	100	1			
12	160	100	1			
14	160	100	1			
16	160	100	1			
Puntero 250 mm			1			
Cinzel 20 x 250 mm			1			

**SDS-V-PLUS (5 piezas)**



**MAK 2**



Ø (mm)	Largo (mm)	Long. útil (mm)	Uds.	Código	EAN	P.V.P. (€)
5	110	50	1	B-49052	0088381457460	15,60
6	110	50	1			
8	110	50	1			
6	160	100	1			
8	160	100	1			

**V-PLUS (7 piezas)**



**MAK 2**



Ø (mm)	Largo (mm)	Long. útil (mm)	Uds.	Código	EAN	P.V.P. (€)
5	110	50	1	B-49046	0088381457453	31,00
6	110	50	1			
8	110	50	1			
6	160	100	1			
8	160	100	1			
10	160	100	1			
12	160	100	1			

**SDS-PLUS StandMak**



Ø (mm)	Largo (mm)	Long. útil (mm)	Uds.	Código	EAN	P.V.P. (€)
6,5	160	100	1	D-74728	0088381589291	8,80
8	160	100	1			
10	160	100	1			
12	160	100	1			
5	110	50	1	D-74136	0088381587174	8,80
6	160	100	1			
8	160	100	1			
10	160	100	1			

**Estuche de brocas para hormigón / ladrillo**



Ø (mm)	Largo (mm)	Uds.	Código	EAN	P.V.P. (€)
6-8-10-12	160	1	D-74756	0088381590181	9,40

**Set brocas para martillos SDS-PLUS 4pcs**



**Estuche de brocas SDS-PLUS**



Ø (mm)	Largo (mm)	Uds.	Código	EAN	P.V.P. (€)
6,8(x2) y 10(x2)	110/160	1	B-54704	0088381478427	12,50

**Expositor de cartón con 12 estuches de 4 piezas cada uno.**

Ø (mm)	Largo (mm)	Long. útil (mm)	Uds.	Código	EAN	P.V.P. (€)
5	110	100	1	E-13596-12	0088381592055	149,00
6	160	100	1			
8	160	100	1			
10	160	100	1			



**Estuche StandMak para martillos SDS-PLUS (5 piezas)**



Ø (mm)	Largo (mm)	Long. útil (mm)	Uds.	Código	EAN	P.V.P. (€)
5	110	50	1	D-00795	0088381171182	6,15
6	110	50	1			
8	110	50	1			
6	160	100	1			
8	160	100	1			

**Brocas de corona para martillos SDS-PLUS**



Ø (mm)	Largo (mm)	Uds.	Código	EAN	P.V.P. (€)
40	60	1	P-26191	88381953092	50,00
50	60	1	P-26200	88381953108	58,00
65	60	1	P-26216	88381953115	59,00
80	60	1	P-26222	88381953122	65,00

**Broca de centrado**

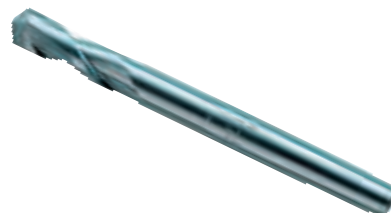

Ø (mm)	Largo (mm)	Punta	Uds.	Código	EAN	P.V.P. (€)
8	120	TCT	1	P-64347	0088381994866	6,70

**Adaptador**



Rosca (mm)	Largo (mm)	Uds.	Código	EAN	P.V.P. (€)
M16	105	1	P-67745	0088381998277	22,00
M16	370	1	P-67751	0088381998284	34,00

**Broca de centrado**



Descripción	Uds.	Código	EAN	P.V.P. (€)
Broca de centrado TCT 19mm	1	D-50441	0088381434430	5,50





**Brocas de corona para mampostería**



Ø (mm)	Largo (mm)	Uds.	Código	EAN	P.V.P. (€)
30	50	1	D-73891	0088381586801	7,70
35	50	1	D-73900	0088381586818	8,20
40	50	1	D-73916	0088381586825	8,60
50	50	1	D-73922	0088381586832	10,00
68	50	1	D-73938	0088381586849	12,90
82	50	1	D-73944	0088381586856	17,70
90	50	1	D-73950	0088381586863	21,00
100	50	1	D-73966	0088381586870	24,00

**Broca de centrado**



Ø (mm)	Largo (mm)	Uds.	Código	EAN	P.V.P. (€)
8	110	1	D-73972	0088381586887	1,75

**Set de broca + adaptador**



Ø (mm)	Largo (mm)	Uds.	Código	EAN	P.V.P. (€)
68	175	1	D-74011	0088381586924	18,70
82	175	1	D-74027	0088381586931	24,00

**Adaptadores**



Ø (mm)	Largo (mm)	Uds.	Rosca	Código	EAN	P.V.P. (€)
110	110	1	M-22	D-73988	0088381586894	4,20
200	200	1		D-73994	0088381586900	6,30
350	350	1		D-74005	0088381586917	8,80





**Brocas para martillos SDS-MAX**

**Más precisión, menos vibración, mayor poder de taladrado.**

- Tres piezas de carburo con geometría de corte única.

Ángulo de pastilla cambiado.



Pastilla biselada en diferentes puntos.

**MAK 4**

- Renovada geometría de la broca 4x90° que evita enganches de la pastilla de carburo en hormigones reforzados. Pastillas laterales muy robustas con forma de corte curva que apoyan a la pastilla central en los cortes rápidos.
- Punta de centrado de 130° para facilitar el inicio del taladrado y garantiza una guía perfecta.
- Cada pastilla lateral lleva marcada una línea que indica el desgaste, así podemos evaluar la precisión de los agujeros de anclaje.
- Pastillas de carburo perfectamente soldadas al cuerpo de acero de la broca.
- Punta de carburo de grandes dimensiones con tecnología patentada de biselado lateral\* para un óptimo taladrado en hormigón reforzado.

\* A partir de ø32mm.

- El diseño de la cabeza de la broca le proporciona una gran dureza, lo que facilita un agresivo efecto de demolición y una alta velocidad de taladrado.
- Diseño de la espiral patentado, con un óptimo rendimiento entre extracción del polvo y resistencia a la rotura.



Ø (mm)	Largo (mm)	Long. útil (mm)	Uds.	Código	EAN	P.V.P. (€)
16	340	200	1	P-77730	0088381708487	39,00
16	540	400	1	P-77746	0088381708494	46,00
16	1320	1180	1	P-77768	0088381708517	162,00
18	340	200	1	P-77774	0088381708524	44,00
18	540	400	1	P-77780	0088381708531	48,00
18	1320	1180	1	P-77805	0088381708555	165,00
20	320	200	1	P-77811	0088381708562	44,00
20	520	400	1	P-77827	0088381708579	50,00
20	920	800	1	P-77833	0088381708586	73,00
22	320	200	1	P-77855	0088381708609	49,00
22	520	400	1	P-77861	0088381708616	54,00
22	920	800	1	P-77877	0088381708623	77,00
22	1320	1200	1	P-77883	0088381708630	179,00
24	320	200	1	P-77899	0088381708647	52,00
24	520	400	1	P-77908	0088381708654	60,00
25	320	200	1	P-77914	0088381708661	51,00
25	520	400	1	P-77920	0088381708678	60,00
25	920	800	1	P-77936	0088381708685	90,00
26	520	400	1	P-77958	0088381708708	65,00
28	370	250	1	P-77964	0088381708715	57,00

Ø (mm)	Largo (mm)	Long. útil (mm)	Uds.	Código	EAN	P.V.P. (€)
28	570	450	1	P-77970	0088381708722	68,00
28	670	550	1	P-77986	0088381708739	88,00
28	920	800	1	P-77992	0088381708746	105,00
28	1320	1200	1	P-78003	0088381708753	196,00
30	370	250	1	P-78019	0088381708760	63,00
30	570	450	1	P-78025	0088381708777	74,00
32*	370	250	1	P-78031	0088381708784	65,00
32*	570	450	1	P-78047	0088381708791	79,00
32*	920	800	1	P-78053	0088381708807	120,00
35	370	250	1	P-78075	0088381708821	78,00
35	570	450	1	P-78081	0088381708838	90,00
35	670	550	1	P-78097	0088381708845	109,00
38	370	250	1	P-78134	0088381708883	94,00
38	570	450	1	P-78140	0088381708890	111,00
40	370	250	1	P-78156	0088381708906	111,00
40	570	450	1	P-78162	0088381708913	134,00
40	920	800	1	P-78178	0088381708920	179,00
40	1320	1200	1	P-78184	0088381708937	244,00
45	570	450	1	P-78190	0088381708944	189,00
50	570	450	1	P-78215	0088381708968	215,00

**Brocas para martillos SDS-MAX**

**TCT - 4 cortes**



- Válidas para hormigón armado



Ø (mm)	Largo (mm)	Long. útil (mm)	Uds.	Código	EAN	P.V.P. (€)
12	340	200	1	E-11324	0088381582605	12,50
12	540	400	1	E-11330	0088381582612	17,20
14	340	200	1	E-11346	0088381582629	15,50
14	540	400	1	E-11352	0088381582636	20,00
16	340	200	1	E-11368	0088381582643	18,40
16	540	400	1	E-11374	0088381582650	23,00
18	340	200	1	E-11380	0088381582667	25,00
18	540	400	1	E-11396	0088381582674	29,00

Ø (mm)	Largo (mm)	Long. útil (mm)	Uds.	Código	EAN	P.V.P. (€)
20	340	220	1	E-11405	0088381582681	29,00
20	540	420	1	E-11411	0088381582698	35,00
22	340	220	1	E-11427	0088381582704	34,00
22	540	420	1	E-11433	0088381582711	40,00
24	340	220	1	E-11449	0088381582728	39,00
24	540	420	1	E-11455	0088381582735	45,00
25	340	220	1	E-11461	0088381582742	40,00
25	540	420	1	E-11477	0088381582759	46,00
28	370	250	1	E-11483	0088381582766	50,00
28	570	450	1	E-11499	0088381582773	61,00
30	370	250	1	E-11508	0088381582780	61,00
30	570	450	1	E-11514	0088381582797	75,00

**Brocas SDS-MAX ESTÁNDAR**



Ø (mm)	Largo (mm)	Long. útil (mm)	Uds.	Código	EAN	P.V.P. (€)
14	340	200	1	D-33897	0088381364553	14,00
14	540	400	1	D-33906	0088381364560	19,00
16	340	200	1	D-33934	0088381364591	16,00
16	540	400	1	D-33940	0088381364607	20,50
18	340	200	1	D-33956	0088381364614	17,00
18	540	400	1	D-33962	0088381364621	22,00
20	320	200	1	D-33978	0088381364638	19,00
20	520	400	1	D-33984	0088381364645	25,50
22	320	200	1	D-33990	0088381364652	20,50
22	520	400	1	D-34001	0088381364669	28,00
24	320	200	1	D-34017	0088381364676	22,00
24	520	400	1	D-34023	0088381364683	29,50
25	320	200	1	D-34039	0088381364690	22,00

Ø (mm)	Largo (mm)	Long. útil (mm)	Uds.	Código	EAN	P.V.P. (€)
25	520	400	1	D-34045	0088381364706	29,00
28	370	250	1	D-34051	0088381364713	25,50
28	570	450	1	D-34067	0088381364720	39,00
30	370	250	1	D-34073	0088381364737	30,00
30	570	450	1	D-34089	0088381364744	49,00
32	370	250	1	D-34095	0088381364751	42,00
32	570	450	1	D-34104	0088381364768	54,00
35	370	250	1	D-34110	0088381364775	51,50
35	570	450	1	D-34126	0088381364782	57,00
38	370	250	1	D-34132	0088381364799	63,00
38	570	450	1	D-34148	0088381364805	76,00
40	370	250	1	D-34154	0088381364812	70,50
40	570	450	1	D-34160	0088381364829	80,00



**Brocas para martillos SDS-MAX**



**4 ventajas significativas:**

1. Mayor vida útil a la broca.
2. Velocidad de perforación superior a la de las brocas convencionales.
3. Rápida eliminación del polvo del taladro = ahorro de tiempo y dinero.
4. Menos vibraciones y energía directamente a la punta de la broca = menos esfuerzo.

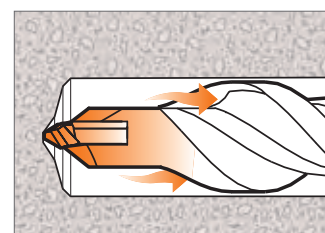

**Brocas MAK2**



**MAK 2**

Ø (mm)	Largo (mm)	Long. útil (mm)	Uds.	Código	EAN	P.V.P. (€)
12	340	200	1	P-17033	0088381943369	33,00
12	540	400	1	P-17049	0088381943376	42,00
12	690	550	1	P-17055	0088381943383	59,00
14	340	200	1	P-17077	0088381943406	37,00
14	540	400	1	P-17083	0088381943413	45,00
15	340	200	1	P-17108	0088381943437	37,00
15	540	400	1	P-17114	0088381943444	46,00







**Brocas de corona para martillos SDS-MAX**



**BROCAS DE CORONA IDEALES PARA TALADRAR HORMIGÓN Y MAMPOSTERÍA:**

- Alineación del diente asimétrica.
- Espiral externa que reduce el peso un 8%.
- Espesor de la pared del diente reducida y diente biselado en la corona para una mejor penetración en el material.
- Dos ranuras asimétricas para evacuar el polvo.



**Brocas de corona para martillos SDS-MAX ★★ ★★**

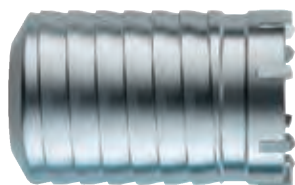

Ø (mm)	Largo (mm)	Uds.	Código	EAN	P.V.P. (€)
40	100	1	P-03779	0088381917438	91,00
50	100	1	P-03785	0088381917445	95,00
65	100	1	P-03791	0088381917452	116,00
80	100	1	P-03800	0088381917469	131,00
90	100	1	P-03816	0088381917476	154,00
100	100	1	P-03822	0088381917483	178,00
125	100	1	P-16374	0088381932394	257,00

**Broca de centrado para martillos SDS-MAX**



Ø (mm)	Largo (mm)	Uds.	Código	EAN	P.V.P. (€)
11	120	1	P-03838	0088381917490	10,00

**Adaptadores**



Tipo	Largo (mm)	Uds.	Código	EAN	P.V.P. (€)
Cónico	180	1	P-16994	0088381943321	46,00
Cónico	450	1	P-17005	0088381943338	64,00

**Cuña**



Uds.	Código	EAN	P.V.P. (€)
1	P-03763	0088381944960	9,40



**Brocas de campana para martillos SDS-MAX**

SDS-MAX ★★★★★

Para el empleo en hormigón, mampostería y piedra natural.:

**Brocas de campana Makita, es el instrumento moderno para los usuarios profesionales. Una broca de corazón poderoso, desarrollado para la última generación de martillos rotativos, garantiza un taladrado eficiente y una vida superior.**



Dientes de carburo con forma de cincel para una rápida penetración del hormigón.

Punta central para mayor precisión.

Tres salidas para retirar grandes cantidades de polvo y desechos.

**Nuevo diseño de los dientes para una vida útil más larga.**

- **Menos vibración.**
- **Más ligeras.**
- **Tratamiento especial contra el calor que incrementa la duración de la broca.**
- **Construcción de una sola pieza para una transmisión perfecta de la fuerza.**

Ø (mm)	Largo (mm)	Uds.	Código	EAN	P.V.P. (€)
40	550	1	E-20080	0088381788700	234,00
45	550	1	E-20096	0088381788717	220,00
45	990	1	E-20105	0088381788724	233,00
55	550	1	E-20111	0088381788731	250,00

Ø (mm)	Largo (mm)	Uds.	Código	EAN	P.V.P. (€)
55	990	1	E-20127	0088381788748	285,00
65	550	1	E-20133	0088381519915	270,00
65	990	1	E-20149	0088381788762	292,00
80	550	1	E-20155	0088381788779	300,00
80	990	1	E-20161	0088381519953	361,00

**Brocas de campana modulares**

★★★★★

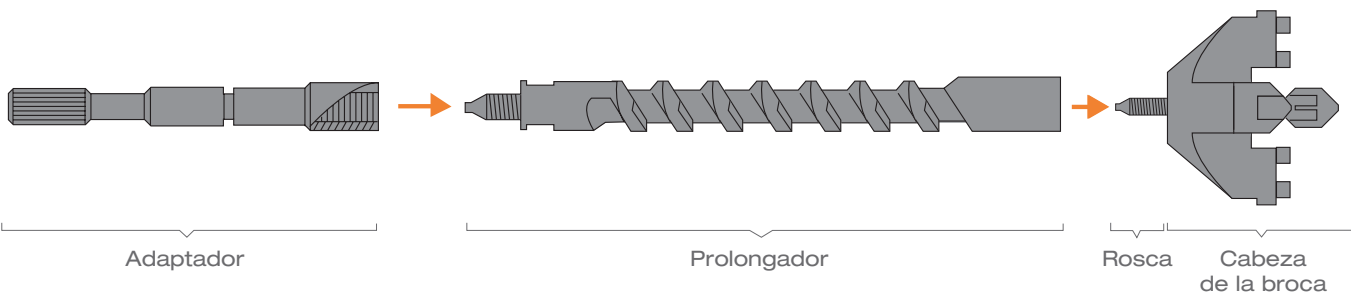

**Adaptadores**

Tipo	Largo (mm)	Uds.	Código	EAN	P.V.P. (€)
SDS-MAX	195	1	P-03888	0088381917544	60,00
B	175	1	P-03894	0088381917551	50,00

**Prolongador**

Ø (mm)	Largo (mm)	Uds.	Código	EAN	P.V.P. (€)
25	280	1	P-03925	0088381917582	97,00

**Rosca con muelle para cabeza**

Ø (mm)	Largo (mm)	Uds.	Código	EAN	P.V.P. (€)
50		1	P-03931	0088381917599	22,00

**Cabeza de broca**

Ø (mm)	Largo (mm)	Modelo	Uds.	Código	EAN	P.V.P. (€)
35	150	HR4003C HR4013C	1	P-04008	0088381945028	138,00
40	150		1	P-03844	0088381917506	146,00
50	150		1	P-03850	0088381917513	178,00
55	150		1	P-04014	0088381945035	196,00
60	150	HR4003C HR4013C HR4501C HR4511C HR5202C HR5212C	1	P-04020	0088381945042	200,00
68	150		1	P-03866	0088381917520	220,00
80	150		1	P-03872	0088381917537	280,00
90	150		1	P-04036	0088381945059	396,00



P-03931

**MAK - Conexión SDS-MAX**

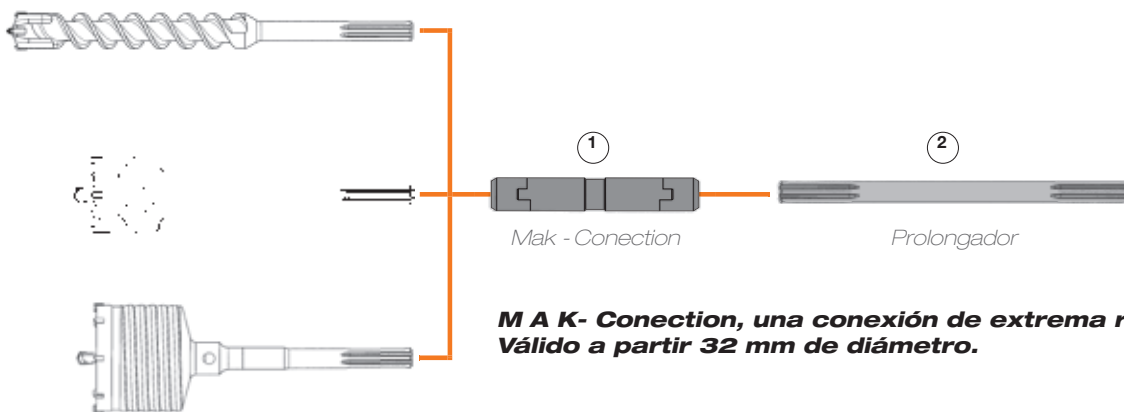

**MAK-Connection, una conexión de extrema robustez. Válido a partir 32 mm de diámetro.**

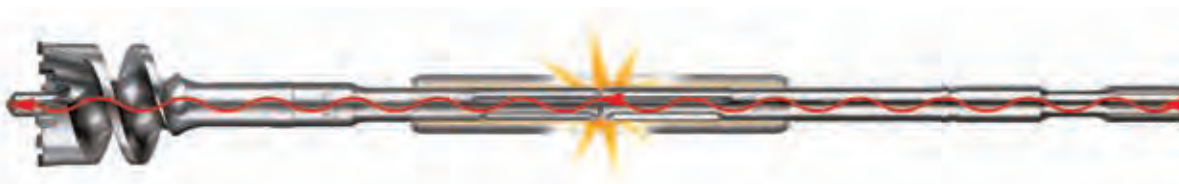

**Sistema de conexión para brocas, MAK-Connection. Una revolución en el universo del taladrado.**

Ventajas del sistema MAK-Connection:

- El sistema SDS-MAX, MAK-Connection, permite una conexión segura y rápida entre la broca y el adaptador.
- Sin pérdidas de energía, contrariamente a los sistemas existentes. La totalidad de la potencia es transmitida a la broca.

**Cambios de inserción**



Descripción	Longitud (mm)	Accesorio	Uds.	Código	EAN	P.V.P. (€)
Mak Conexión	-	SDS-MAX	1	P-53914	0088381984423	204,00
Prolongador	320		1	P-53920	0088381984430	29,00
Prolongador	750		1	P-53936	0088381984447	36,00
Prolongador	1100		1	P-53942	0088381984454	50,00

Descripción	Máquina	Accesorio	Uds.	Código	EAN	P.V.P. (€)
Adaptador	K	SDS-MAX	1	P-02319	0088381944953	157,00
Adaptador	SDS-MAX	SDS-PLUS	1	P-17027	0088381943352	79,00



*Makita*



**SDS-PLUS**

**Punteros**



- Para todo tipo de obras en mampostería, hormigón y piedra suelta.



B-64238

Ancho (mm)	Largo (mm)	Serie	Uds.	Código	EAN	P.V.P. (€)
14	250	Premium ★★★★★	1	B-64238	0088381534444	12,20
14	250	Long life ★★★	1	B-64294	0088381534505	8,30
14	250	Standard ★★	1	D-08713	0088381179522	4,10
14	250	Long life ★★★	1	P-05505	0088381921299	9,90

**Cinceles**



- Para todo tipo de obras en mampostería, hormigón y piedra suelta.



B-64244

Ancho (mm)	Largo (mm)	Serie	Uds.	Código	EAN	P.V.P. (€)
20	250	Premium ★★★★★	1	B-64244	0088381534451	12,20
20	250	Long life ★★★	1	B-64303	0088381534512	8,30
20	250	Standard ★★	1	D-08729	0088381179539	3,90
22	250	Long life ★★★	1	P-05511	0088381921305	9,90

**Espátulas**



- Para la demolición universal en materiales de mayor volumen.



Ancho (mm)	Largo (mm)	Serie	Uds.	Código	EAN	P.V.P. (€)
40	250	Premium ★★★★★	1	E-20177	0088381788793	19,00
40	250	Long life ★★★	1	B-64319	0088381534529	12,30
40	250	Standard ★★	1	D-08735	0088381179546	5,20
40	250	Long life ★★★	1	P-05527	0088381921312	14,90
50	215	Standard ★★	1	D-25616	0088381338431	5,60

**Espátula para asfalto**



- Para la obra en carretera, por ejemplo, en el saneamiento de superficies u otras reparaciones de calzada.



P-24935

Ancho (mm)	Largo (mm)	Serie	Uds.	Código	EAN	P.V.P. (€)
60	250	Long life ★★★	1	P-24935	0088381951845	18,20

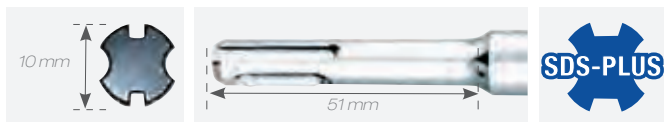

**Espátula dentada**



- Para sanear muros, eliminar masilla de juntas.



P-25096

Ancho (mm)	Largo (mm)	Serie	Uds.	Código	EAN	P.V.P. (€)
32	200	Long life ★★★	1	P-25096	0088381952002	72,00

**Espátulas curvas**



- Retirada de azulejos de forma fácil y sencilla (con extremo acodado de forma ergonómica).



P-24941

Ancho (mm)	Largo (mm)	Serie	Uds.	Código	EAN	P.V.P. (€)
40	200	Long life ★★★	1	P-24941	0088381951852	13,80
50	250	Standard ★★	1	D-78324	0088381951869	7,50
50	250	Premium ★★★★★	1	E-20183	0088381788809	21,00
60	250	Long life ★★★	1	P-24957	0088381951869	19,30

**Escoplos**



- Para acanalar en mampostería.



P-05533

Ancho (mm)	Largo (mm)	Serie	Uds.	Código	EAN	P.V.P. (€)
22	250	Long life	1	P-05533	0088381921329	16,00
22	240	★★★	1	P-25080	0088381951999	14,90

**Escoplo acanalado con aletas**



- Para tratamiento de piedra caliza, hormigón, ladrillos, piedra pómez, especialmente efectivo y seguro debido a su profundidad de acanalado variable de 10-35 mm. sin resbalar hacia el interior del surco.



P-24963

Ancho (mm)	Largo (mm)	Serie	Uds.	Código	EAN	P.V.P. (€)
22	250	Long life ★★★	1	P-24963	0088381951876	30,00

**SDS-PLUS**

**Formones**



- Para trabajos de carpintería en general, rápido arranque de material de madera blanda, por ejemplo para arrancar marcos de ventanas viejos.

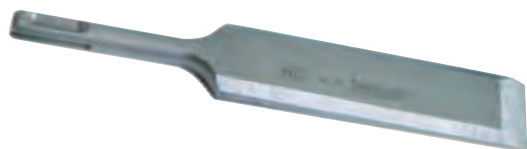

P-25111

Ancho (mm)	Largo (mm)	Serie	Uds.	Código	EAN	P.V.P. (€)
20	170	Long life	1	P-25105	0088381952019	20,00
30	170	★★★	1	P-25111	0088381952026	29,00

**Raspador**



- Para levantar moquetas y retirar pegamentos de superficies rígidas.



A-68161

Ancho (mm)	Descrip.	Tipo	Uds.	Código	EAN	P.V.P. (€)
100	Raspador	-	1	A-68161	0088381537254	86,00
-	Cuchilla	Para A-68161	1	343411-9	0088381118415	31,00

**Set de demolición**



Contenido	Uds.	Código	EAN	P.V.P. (€)
Puntero 14 x 250mm	1	D-05181	0088381177450	26,00
Cinzel 20 x 250mm	1			
Espátula 40 x 250mm	1			

**Set de demolición**



Contenido	Uds.	Código	EAN	P.V.P. (€)
Puntero 14 x 250mm	2	D-16368	0088381187848	37,00
Cinzel 20 x 250mm	2			
Espátula 40 x 250mm	1			

**Set de demolición**



Contenido	Uds.	Código	EAN	P.V.P. (€)
Puntero 250mm	1	D-42357	0088381404815	32,00
Cinzel 20 x 250mm	1			
Espátula 40 x 250mm	1			

**Set de demolición**



Contenido	Uds.	Código	EAN	P.V.P. (€)
Puntero 230mm	1	D-71314	0088381560481	10,00
Cinzel 20 x 230mm	1			
Espátula 40 x 230mm	1			

**SDS-MAX**

**Punteros**

- Para todo tipo de obras en mampostería, hormigón y piedra suelta.



B-10366

D-34182-10

Ancho (mm)	Largo (mm)	Serie	Uds.	Código	EAN	P.V.P. (€)
18	280	Long life ★★★	1	P-16237	0088381932264	8,90
18	400		1	P-16243	0088381932271	12,70
18	600		1	P-16259	0088381932288	18,00
18	300	Standard ★★	1	D-34176	0088381364836	6,20
18	400		1	D-34182	0088381364843	7,80
18	400		10	D-34182-10	0088381367240	71,00
18	600		1	D-34198	0088381364850	10,00
18	400	Autoafilable espiral ★★★★	1	B-23064	0088381406161	21,00

**Cinceles**

- Para todo tipo de obras de mampostería, hormigón y piedra suelta.



P-16265

D-34213-10

Ancho (mm)	Largo (mm)	Serie	Uds.	Código	EAN	P.V.P. (€)
25	280	Long life ★★★	1	P-16265	0088381932295	8,90
25	400		1	P-16271	0088381932301	12,70
25	600		1	P-16287	0088381932318	18,00
25	300	Standard ★★	1	D-34207	0088381364867	6,20
25	400		1	D-34213	0088381364874	8,10
25	400		10	D-34213-10	0088381367257	76,00
25	600		1	D-34229	0088381364881	9,60

**Set de 5 punteros y 5 cinceles**

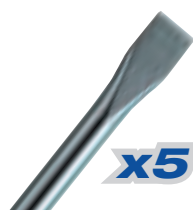

Ancho (mm)	Largo (mm)	Serie	Uds.	Código	EAN	P.V.P. (€)
18	400	Standard ★★	5	D-35324-10	0088381367905	65,00
25	400		5			

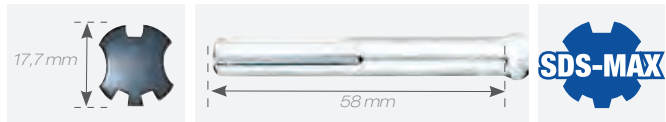

**Espátulas**

- Para la demolición en material de mayor volumen.



P-16302

Ancho (mm)	Largo (mm)	Serie	Uds.	Código	EAN	P.V.P. (€)
50	350	Long life ★★★	1	P-16302	0088381932332	17,10
80	300		1	P-16318	0088381932349	26,00
50	400	Standard ★★	1	D-34235	0088381364898	8,80
80	300		1	D-34241	0088381364904	14,30

**Espátula curva**

- Retirada de azulejos de forma fácil y sencilla. Con extremo acodado de forma ergonómica.



P-16324

Ancho (mm)	Largo (mm)	Serie	Uds.	Código	EAN	P.V.P. (€)
50	300	Long life ★★★	1	P-16324	0088381932356	26,00
50	400		★★	1	D-78330	197050350695

**Espátula dentada**

- Para sanear muros, por ejemplo, para eliminar masilla de juntas.



P-16346

Ancho (mm)	Largo (mm)	Serie	Uds.	Código	EAN	P.V.P. (€)
38	280	Long life ★★★	1	P-16346	0088381932370	78,00

**Escoplo**

- Para acanalar en mampostería.



P-16293

Ancho (mm)	Largo (mm)	Serie	Uds.	Código	EAN	P.V.P. (€)
26	300	Long life ★★★	1	P-16293	0088381932325	28,00



**SDS-MAX**

**Escoplo acanalado con aletas**



- Para acanalar en piedra caliza, hormigón, ladrillos, piedra pómez, especialmente efectivo y seguro debido a su profundidad de acanalado variable de 10-35 mm. sin resbalar hacia el interior del surco.



Ancho (mm)	Largo (mm)	Serie	Uds.	Código	EAN	P.V.P. (€)
35	380	Long life ★★★	1	P-16330	0088381932363	55,00

**Pala**



- Perfecta para sacar tierra.



Ancho (mm)	Largo (mm)	Serie	Uds.	Código	EAN	P.V.P. (€)
110	400	Long life ★★★	1	P-23721	0088381950664	57,00

**Pisón**



- Para compactar materiales blandos.



Adaptador

Pisón

Ø (mm)	Descripción	Serie	Uds.	Código	EAN	P.V.P. (€)
140	Pisón	Long life	1	A-19875	0088381158985	89,00
-	Adaptador pisón	★★★	1	A-19897	0088381159005	43,00

**Bujarda**



- Para abujardar zonas de piedra u hormigón.



Adaptador

Base

Medida (mm)	Descripción	Serie	Uds.	Código	EAN	P.V.P. (€)
60x60	Base	Long life	1	P-03947	0088381932820	87,00
250	Adaptador	★★★	1	P-16352	0088381932387	32,00

**Adaptador para picas de toma de tierra**

- Para clavar las picas en tierra.



502024

Ø (mm)	Largo (mm)	Serie	Uds.	Código	EAN	P.V.P. (€)
13	260	Long life ★★★	1	502024	-	39,00
16	260		1	P-63797	0088381994316	44,00
19	260		1	502026	-	50,00
22,2	260		1	E-13041	0088381590211	61,00

**Estuches SDS-MAX**



Contenido	Serie	Uds.	Código	EAN	P.V.P. (€)
Punteros	Standard ★★	2	D-40565	0088381403405	71,00
Cinceles		2			
Espátulas		2			



Contenido	Serie	Uds.	Código	EAN	P.V.P. (€)
Puntero	Standard ★★	1	D-42450	0088381404914	49,00
Cinzel		1			
Espátula		1			

## Makita Hexagonal 30mm

- Para modelos **HM1317C, HM1307C, \*HM1400, HM1501 y HM1511.**

### Punteros

- Para todo tipo de obras en mampostería, hormigón y piedra suelta.



B-10388

Ancho (mm)	Largo (mm)	Serie	Uds.	Código	EAN	P.V.P. (€)
30	410	Standard ★★	1	D-15285	0088381186377	20,00
30	400	Long life ★★★	1	P-05549	0088381921336	35,00
30	400		1	B-10388*	0088381342483	37,00
30	700		1	P-05561	0088381921350	53,00

\*autoafilable

### Espátulas

- Para la demolición en material de mayor volumen.



D-23868

Ancho (mm)	Largo (mm)	Serie	Uds.	Código	EAN	P.V.P. (€)
75	310	Standard ★★	1	D-23868	0088381313094	23,00
75	310		1	D-34805*	0088381365802	23,00
115	400	Long life ★★★	1	P-13518	0088381943239	84,00

\*especial para suelo

- Para modelo **HM1400.**

Ancho (mm)	Largo (mm)	Serie	Uds.	Código	EAN	P.V.P. (€)
110	400	Long life ★★★	1	P-13493	0088381943215	85,00



### Cinceles

- Para todo tipo de obras de mampostería, hormigón y piedra suelta.



D-15300

Ancho (mm)	Largo (mm)	Serie	Uds.	Código	EAN	P.V.P. (€)
30	400	Standard ★★	1	D-15300	0088381186384	20,00
32	410	Long life ★★★	1	P-13487	0088381943208	35,00

- Para modelo **HM1400**

Ancho (mm)	Largo (mm)	Serie	Uds.	Código	EAN	P.V.P. (€)
32	400	Long life ★★★	1	P-13502	0088381943222	35,00
32	700		1	P-05583	0088381921374	54,00

### Pisón



A-31485

Ø (mm)	Serie	Uds.	Código	EAN	P.V.P. (€)
200	Long life ★★★	1	A-31485	0088381151610	123,00

### Pala

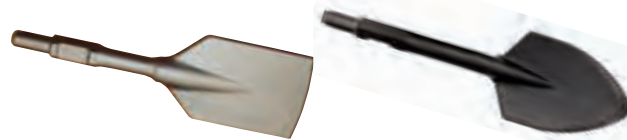

P-05555

B-10300

Ancho (mm)	Largo (mm)	Tipo	Uds.	Código	EAN	P.V.P. (€)
125	400	Long life ★★★	1	P-05555	0088381921343	89,00
120	500	Standar ★★	1	B-10300	0088381341288	106,00

- Para modelo **HM1400**

Ancho (mm)	Largo (mm)	Serie	Uds.	Código	EAN	P.V.P. (€)
125	400	Long life ★★★	1	P-05608	0088381921398	89,00

**Makita Hexagonal 28,6mm**

- Para modelos **HM1317CB, HM1304B, HM1512, HM1801, HM1810 y HM1812.**

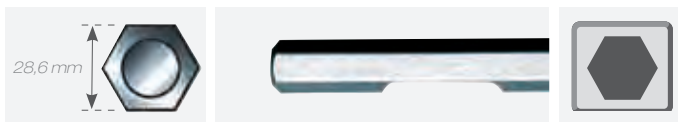

**Punteros**



- Para todo tipo de obras en mampostería, hormigón y piedra suelta.



P-05692

Ancho (mm)	Largo (mm)	Serie	Uds.	Código	EAN	P.V.P. (€)
28,6	400	Long life	1	P-05692	0088381921480	32,50
28,6	600	★★★	1	P-64272	0088381994798	72,00
28,6	400	Premium ★★★★★	1	B-10372*	0088381342476	34,00

\*autoafilable



D-17631

Ancho (mm)	Largo (mm)	Serie	Uds.	Código	EAN	P.V.P. (€)
28,6	400	Long life	1	D-17631	0088381197182	20,00
28,6	600	★★★	1	P-65931	0088381996464	50,00

**Cinceles**



- Para todo tipo de obras de mampostería, hormigón y piedra suelta.

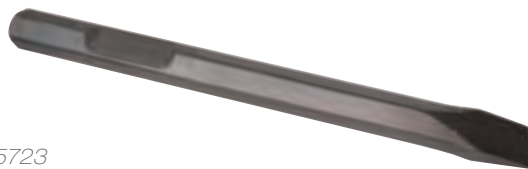

P-05723

Ancho (mm)	Largo (mm)	Serie	Uds.	Código	EAN	P.V.P. (€)
35	400	Long life	1	P-05723	0088381921510	33,00
30	600	★★★	1	P-64288	0088381994804	58,00



P-65947

Ancho (mm)	Largo (mm)	Serie	Uds.	Código	EAN	P.V.P. (€)
28	410	Standard ★★	1	D-17647	0088381197199	20,00
30	600	Long life ★★★★★	1	P-65947	0088381996471	42,00

**Espátulas**



- Para la demolición en material de mayor volumen.



P-05701

Ancho (mm)	Largo (mm)	Serie	Uds.	Código	EAN	P.V.P. (€)
75	410	Standard ★★	1	D-29228*	0088381345682	21,00
80	400	Long life ★★★★★	1	P-05701	0088381921497	60,00

\* con anilla

**Pala**



P-05717

Ancho (mm)	Largo (mm)	Serie	Uds.	Código	EAN	P.V.P. (€)
125	400	Long life ★★★★★	1	P-05717	0088381921503	82,00

**Pisón**



798385-3

Ø (mm)	Serie	Uds.	Código	EAN	P.V.P. (€)
200	Long life ★★★★★	1	798385-3	0088381127554	217,00

- **Uso de puntero con anilla**

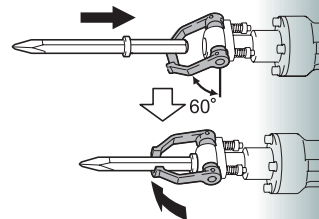

- **Uso de puntero con rebaje**

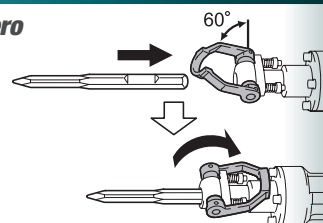



**Set eje - mandril para martillos SDS-MAX**



Descripción	Rosca	Inserción	Uds.	Código	EAN	P.V.P. (€)
Set	1/2"	SDS-MAX	1	122829-5	0088381435901	65,00

**Adaptador 1/2" a SDS-MAX**

(para sacar brocas que se han quedado bloqueadas)



\* Utilizar con llaves de impacto de 1/2".

Tipo	Uds.	Código	EAN	P.V.P. (€)
1/2"	1	195870-1	0088381398336	126,00

**Gancho para HR008**



Descripción	Uds.	Código	EAN	P.V.P. (€)
Práctico gancho para HR008	1	191W90-3	-	10,50

**Set eje - mandril para martillos SDS-PLUS**



con portabrocas

Descripción	Rosca	Inserción	Uds.	Código	EAN	P.V.P. (€)
Set	1/2"	SDS-PLUS	1	P-18150	0088381944472	48,00
Adaptador	1/2"	SDS-PLUS	1	D-14093	0088381359450	2,80

**Perilla de soplado**



Uds.	Código	EAN	P.V.P. (€)
1	765009-6	0088381102377	2,45

**Aceite grafitado**



Contenido (gr)	Uds.	Código	EAN	P.V.P. (€)
30	1	P-08361	0088381913072	3,30

**Paño para limpieza**



Uds.	Código	EAN	P.V.P. (€)
1	443122-7	0088381205658	3,30

**Grasa para broca**



Contenido (gr)	Uds.	Código	EAN	P.V.P. (€)
30	1	183477-5	0088381373760	4,10
100	1	198993-4	0088381518994	6,60



**Brocas de corona Unicut para mampostería y azulejo**

**Broca de corona**

★★★★



Ø (mm)	Largo (mm)	Modelos	Uds.	Código	EAN	P.V.P. (€)
25	60	Martillos ligeros hasta 26 mm	1	D-42690	0088381405157	15,50
30	60		1	D-42715	0088381405171	17,25
35	60		1	D-42737	0088381405195	17,50
40	60		1	D-42759	0088381405218	18,50
45	60		1	D-42765	0088381405225	20,00
50	60		1	D-42787	0088381405249	22,00
55	60		1	D-42818	0088381405270	24,00
60	60		1	D-42830	0088381405294	25,00
65	60		1	D-42852	0088381405317	26,00
68			1	D-42874	0088381405331	27,00
70	60		1	D-42880	0088381405348	28,00
76	60		1	D-45032	0088381407274	29,00
80	60	Martillos ligeros a partir de 28 mm	1	D-45331	0088381407458	31,00
85	60		1	D-45353	0088381407472	36,00
105	60		1	D-50326	0088381434317	48,00

**Adaptador para brocas UNICut SDS-plus**



Ø (mm)	Largo (mm)	Uds.	Rosca	Punta	Código	EAN	P.V.P. (€)
10	100	1	M-16	TCT	D-50348	0088381434331	9,75
8	100	1		HSS	D-50382	0088381434379	9,50

**Broca de centrado para brocas Unicut**



Ø (mm)	Largo (mm)	Punta	Uds.	Código	EAN	P.V.P. (€)
8	120	TCT	1	P-64347	0088381994866	6,70

**Broca de centrado para multiusos**



Ø (mm)	Largo (mm)	Punta	Uds.	Código	EAN	P.V.P. (€)
8	90		1	D-50441	0088381434430	5,50

**UNICut**

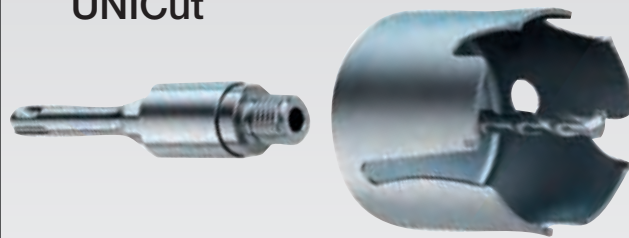

Las brocas UNICut son diseñadas para el empleo en una amplia gama de materiales:

- Albañilería con mampostería, ladrillos, azulejos, etc.
- Materiales ligeros como tabla de yeso, tabi, Fermacell, etc.
- En plástico, madera prensada, contrachapado, etc.

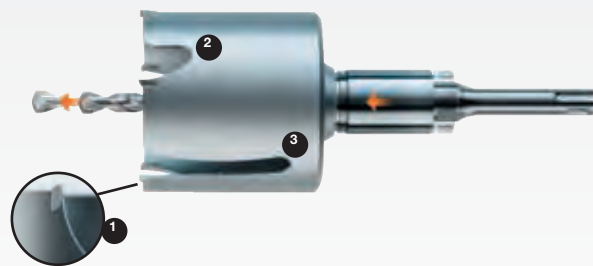

UNICut ¡ventajas convincentes!:

- 1 Robusta y duradera: Los dientes de carburo, con una superficie más amplia, soldados (1) de forma semejante al de una caja fuerte, aseguran y garantizan que los dientes no se desprenderán de la broca.
- 2 Rápida progresión taladrando: debido a la robusta estructura y corte agresivos.
- 3 Optimizando la vida del cuerpo: La vibración ha sido mejorada debido a la geometría especial de las cámaras de desalajo ampliadas (2) y la ranura de extracción de gases (3).



**Brocas para ladrillo** ★★



Ø (mm)	Largo (mm)	Uds.	Código	EAN	P.V.P. (€)
3	60	1	D-05228	0088381176453	1,25
4	70	1	D-05234	0088381176460	1,25
5	85	1	D-05240	0088381176477	1,25
6	100	1	D-05256	0088381176484	1,25
6	150	1	D-05262	0088381176491	1,25
7	100	1	D-05278	0088381176507	1,25
7	150	1	D-05284	0088381176514	1,25
8	110	1	D-05290	0088381176521	1,25
8	150	1	D-05309	0088381176538	1,25
9	150	1	D-05315	0088381176545	1,25
10	150	1	D-05321	0088381176552	1,55
11	150	1	D-05337	0088381176569	1,55
12	150	1	D-05343	0088381176576	2,15
13	150	1	D-05359	0088381176583	2,80
14	150	1	D-05365	0088381176590	2,80
15	150	1	D-05371	0088381176606	2,80
16	150	1	D-05387	0088381176613	3,10

**Brocas para ladrillo TCT** ★★★



Ø (mm)	Largo (mm)	Uds.	Código	EAN	P.V.P. (€)
3	60	1	E-06351	0088381569309	1,50
4	70	1	E-06367	0088381569316	1,50
5	85	1	E-06373	0088381569323	1,50
5	150	1	E-06389	0088381569330	1,50
6	100	1	E-06410	0088381569361	1,50
6	150	1	E-06426	0088381569378	1,50
8	110	1	E-06482	0088381569439	1,50
8	150	1	E-06498	0088381569446	1,50
10	150	1	E-06529	0088381569477	1,50
10	250	1	E-06535	0088381569484	3,05
12	150	1	E-06541	0088381569491	2,40
12	250	1	E-06557	0088381569507	3,30
14	150	1	E-06563	0088381569514	3,05
14	250	1	E-06579	0088381569521	4,20
16	150	1	E-06585	0088381569538	3,40
18	200	1	E-06591	0088381569545	4,90
20	200	1	E-06600	0088381569552	5,50

**Brocas para ladrillo 1/4" hexagonal** ★★



Ø (mm)	Largo (mm)	Uds.	Código	EAN	P.V.P. (€)
5	90	1	D-23793	0088381312882	2,10
6	100	1	D-23802	0088381312899	2,15
8	100	1	D-23818	0088381312905	2,90



**Brocas punta de flecha 1/4" hexagonal** ★★★



D-15986



D-15942

Ø (mm)	Largo (mm)	Uds.	Código	EAN	P.V.P. (€)
4	65	1	D-15942	0088381187107	2,80
5	65	1	D-15958	0088381187114	2,80
6	65	1	D-15964	0088381187121	3,05
8	70	1	D-15970	0088381187138	3,05
10	80	1	D-15986	0088381187145	3,70

**Brocas cilíndricas para vidrio / baldosas**



Ø (mm)	Largo (mm)	Uds.	Código	EAN	P.V.P. (€)
3	51	1	D-78405	197050351432	2,00
4	51	1	D-78411	197050351449	2,00
5	51	1	D-78427	197050351456	2,00
6	58	1	D-78433	197050351463	2,50
8	58	1	D-78455	197050351487	2,75
10	96	1	D-78461	197050351494	3,25





**Brocas multimaterial**

**Omn|Bohrer** *Cilíndricas* ★★



Ø (mm)	Largo (mm)	Largo útil (mm)	Uds.	Código	EAN	P.V.P. (€)
3	60	26	1	D-30287	0088381353151	0,90
4	70	36	1	D-30293	0088381353168	0,90
5	85	41	1	D-30302	0088381353175	0,90
5,5	100	56	1	D-31033	0088381355056	0,90
6	150	101	1	D-30324	0088381353199	0,95
6	250	170	1	D-72780	0088381577298	1,80
6,5	100	56	1	D-31061	0088381355087	0,95
7	150	101	1	D-30346	0088381353212	1,25
8	150	95	1	D-30368	0088381353236	1,25
9	150	95	1	D-30374	0088381353243	1,50
10	150	95	1	D-30380	0088381353250	1,55
12	150	91	1	D-30411	0088381353281	2,15
12	400	298	1	D-30427	0088381353298	4,60
13	150	83	1	D-30449	0088381353342	2,45
14	150	83	1	D-30455	0088381353311	2,80
14	400	298	1	D-30461	0088381353328	6,20

**Omn|Bohrer** *Cilíndricas* ★★★



Ø (mm)	Largo (mm)	Largo útil (mm)	Uds.	Código	EAN	P.V.P. (€)
3	70	38	1	E-10958	0088381581615	1,60
4	75	40	1	E-10964	0088381581622	1,60
5	85	43	1	E-10970	-	1,70
5,5	100	50	1	E-10986	0088381581646	1,85
6	150	90	1	E-11003	0088381581660	2,20
6,5	150	90	1	E-11025	0088381581684	2,35
7	100	50	1	E-11031	0088381581691	2,20
8	150	90	1	E-11053	0088381581714	2,95
10	150	90	1	E-11069	0088381581721	3,50
12	150	90	1	E-11075	0088381581738	3,90
13	150	90	1	E-11081	0088381581745	4,80

**Omn|Bohrer** *1/4" Hex* ★★★

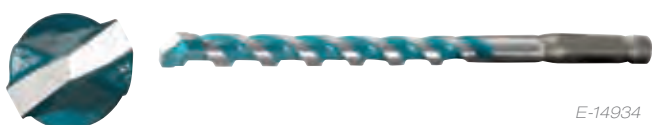

E-14934

Ø (mm)	Largo (mm)	Uds.	Código	EAN	P.V.P. (€)
3	90	1	E-14934	0088381594899	1,85
4	90	1	E-14940	0088381594905	1,85
5	100	1	E-14956	0088381594912	2,15
6	100	1	E-14984	0088381594943	2,40
6	150	1	E-14990	0088381594950	2,65
8	120	1	E-15045	0088381595001	3,20
8	150	1	E-15051	0088381595018	3,50
10	150	1	E-15067	0088381595025	4,00
12	150	1	E-15073	0088381595032	4,50
13	150	1	E-15089	0088381595049	5,40

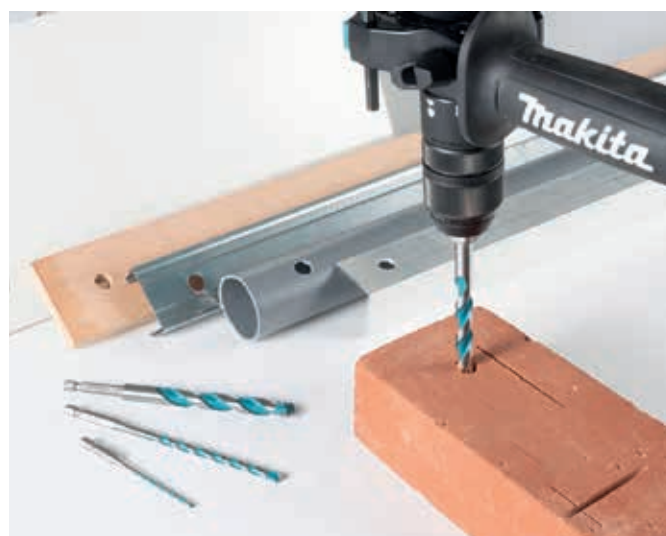

**Omn|Bohrer** *Inserción 1/4" Hex* ★★★



Descripción	Uds.	Código	EAN	P.V.P. (€)
Set de brocas multimaterial, 5pcs	1	E-16732	0088381786645	20,00

**Omn|Bohrer** ★★★



Ø (mm)	Largo (mm)	Uds.	Código	EAN	P.V.P. (€)
4/5/6/8/10 (estuche)	75/85/100/120/150	1	E-14255	0088381593526	12,80

**Brocas estándar para madera**

★★★

- Con punta centradora.



Ø (mm)	Largo (mm)	Largo útil (mm)	Uds.	Código	EAN	P.V.P. (€)
3	60	33	1	D-07026	0088381178587	0,95
4	75	43	1	D-07032	0088381178594	0,95
5	85	52	1	D-07048	0088381178600	0,95
6	95	57	1	D-07054	0088381178617	0,90
6	315	160	1	D-07157	0088381178716	3,30
7	110	69	1	D-07060	0088381178624	1,25
8	115	75	1	D-07076	0088381178631	1,25
8	315	160	1	D-07163	0088381178723	3,60
9	125	81	1	D-07082	0088381178648	1,55
10	135	87	1	D-07098	0088381178655	1,55
10	315	160	1	D-07179	0088381178730	4,40
12	155	101	1	D-07107	0088381178662	2,20
12	315	160	1	D-07185	0088381178747	5,30
13	151	96	1	D-53453	0088381449373	2,85
14	170	108	1	D-07113	0088381178679	2,80
14	315	160	1	D-07191	0088381178754	6,30
15	160	100	1	D-53469	0088381449380	3,50
16	180	105	1	D-07129	0088381178686	4,40
16	315	160	1	D-07200	0088381178761	7,50
18	200	120	1	D-07135	0088381178693	6,30
18	335	160	1	D-07216	0088381178778	10,10
20	200	130	1	D-07141	0088381178709	6,90
20	335	160	1	D-07222	0088381178785	12,60

**Brocas helicoidales para madera**

★★★

- Ideal para taladros pasantes.
- Gran extracción de viruta.
- Punta autorroscante.



Ø (mm)	Largo (mm)	Largo útil (mm)	Uds.	Código	EAN	P.V.P. (€)
6	250	180	1	D-07331	0088381178891	3,50
8	250	180	1	D-07347	0088381178907	3,60
8	450	380	1	D-07559	0088381179119	7,60
10	250	180	1	D-07353	0088381178914	5,60
10	450	380	1	D-07565	0088381179126	8,20
12	250	180	1	D-07369	0088381178921	6,10
12	450	380	1	D-07571	0088381179133	9,40
13	250	180	1	D-53475	0088381449397	6,40
13	450	380	1	D-53497	0088381449410	10,20
14	250	180	1	D-07375	0088381178938	7,00
14	450	380	1	D-07587	0088381179140	10,20
15	250	180	1	D-53481	0088381449403	7,00
15	450	380	1	D-53506	0088381449427	11,40
16	250	180	1	D-07381	0088381178945	7,30
16	450	380	1	D-07593	0088381179157	11,90
18	250	180	1	D-07397	0088381178952	8,20
18	450	380	1	D-07602	0088381179164	13,40
20	250	180	1	D-07406	0088381178969	8,50
20	450	380	1	D-07618	0088381179171	15,30
22	250	180	1	D-07412	0088381178976	9,00
22	450	380	1	D-07624	0088381179188	16,90
24	250	180	1	D-07428	0088381178983	9,60
24	450	380	1	D-07630	0088381179195	18,90
26	450	380	1	D-07646	0088381179201	22,00
28	450	380	1	D-07652	0088381179218	25,00
30	450	380	1	D-07668	0088381179225	29,00

**Brocas estándar para madera 1/4" hexagonal**

★★★



Ø (mm)	Largo (mm)	Largo útil (mm)	Uds.	Código	EAN	P.V.P. (€)
3	75	33	1	D-15861	0088381187022	1,25
4	90	43	1	D-15877	0088381187039	1,25
5	100	52	1	D-15883	0088381187046	1,55
6	110	57	1	D-15899	0088381187053	1,55
8	115	75	1	D-15908	0088381187060	2,20
10	130	87	1	D-15914	0088381187077	2,50
12	150	101	1	D-15920	0088381187084	3,40
15	160	108	1	D-15936	0088381187091	5,40

**Brocas helicoidales para madera 1/4" hexagonal**

★★★



Ø (mm)	Largo (mm)	Largo útil (mm)	Uds.	Código	EAN	P.V.P. (€)
6	200	130	1	D-15992	0088381187152	4,30
8	200	130	1	D-16003	0088381187169	4,90
10	200	130	1	D-16019	0088381187176	5,80
12	200	130	1	D-16025	0088381187183	6,20
14	200	130	1	D-16031	0088381187190	6,10
16	200	130	1	D-16047	0088381187206	6,30
18	200	130	1	D-16053	0088381187213	7,00
20	200	130	1	D-16069	0088381187220	8,10
21	200	130	1	D-16075	0088381187237	10,20

**Brocas de pala para madera** ★★

- Con punta centradora.
- Gran velocidad de taladrado.



Ø (mm)	Largo (mm)	Uds.	Código	EAN	P.V.P. (€)
6	150	1	D-07674	0088381179232	1,55
8	150	1	D-07680	0088381179249	1,55
10	150	1	D-07696	0088381179256	1,55
12	150	1	D-07705	0088381179263	1,85
13	150	1	D-67614	0088381549363	1,85
14	150	1	D-07711	0088381179270	1,85
15	150	1	D-07727	0088381179287	1,85
16	150	1	D-07733	0088381179294	1,85
18	150	1	D-07749	0088381179300	2,20
20	150	1	D-07755	0088381179317	2,20
22	150	1	D-07761	0088381179324	2,20
24	150	1	D-07777	0088381179331	2,85
25	150	1	D-07783	0088381179348	2,85
26	150	1	D-07799	0088381179355	2,85
28	160	1	D-07808	0088381179362	3,10
30	160	1	D-07814	0088381179379	3,40
32	160	1	D-07820	0088381179386	3,80
34	160	1	D-07836	0088381179393	4,10
35	160	1	D-07842	0088381179409	4,10
36	160	1	D-07858	0088381179416	4,40

**Brocas de precisión Forstner para madera** ★★

- Perforaciones perfectas, con menos rebabas.
- Menos ruido.
- Menos esfuerzo.
- Presentado en bote de plástico con gancho para colgar.
- El diseño de los dientes ofrece una alta precisión y un gran rendimiento.
- Punta centradora que permite un preciso inicio de taladrado.
- Medida marcada en la broca para reconocerla fácilmente.
- Puede utilizarse en taladros con portabrocas de 10mm y 13mm.



Ø (mm)	Largo (mm)	Uds.	Código	EAN	P.V.P. (€)
10	90	1	D-41844	0088381404648	6,60
15	90	1	D-41925	0088381404686	7,80
20	90	1	D-42232	0088381404693	8,90
25	90	1	D-42248	0088381404709	9,60
26	90	1	D-42254	0088381404716	10,20
30	90	1	D-42260	0088381404723	10,70
35	90	1	D-42282	0088381404747	11,90
40	90	1	D-42298	0088381404754	13,70
50	90	1	D-42307	0088381404761	18,80

**Estuche de brocas para madera** ★★



Descripción	Ø (mm)	Largo (mm)	Uds.	Código	EAN	P.V.P. (€)
Estuche de brocas madera (5pcs)	6	200	1	D-75677	0088381790161	23 €
	8					
	13					
	16					
	19					

**Estuche de brocas Forstner para madera** ★★



Descripción	Ø (mm)	Largo (mm)	Uds.	Código	EAN	P.V.P. (€)
Estuche de brocas Forstner madera (5pcs)	15	90	1	D-47363	0088381426893	35 €
	20					
	25					
	30					
	35					



**Brocas para metal HSS-R DIN338**



- Brocas indicadas para el taladrado de acero con resistencia máxima de 900 N/mm<sup>2</sup>, hierro fundido, plásticos y metales no ferrosos.
- Mínimo riesgo de rotura para diámetros pequeños gracias a la posibilidad de flexión del material.
- Espiral con dos salidas para una efectiva evacuación del material sobrante.
- Brocas para corte en metal con un ángulo en la punta de 118°.
- Bisel en los bordes de la espiral para una mejor evacuación de la viruta.

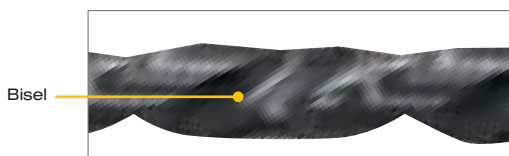

- Blíster con dos Uds. en las brocas con medidas comprendidas entre 1.5 – 4.0mm.
- Brocas de categoría estándar con muy buena relación calidad precio.

Ø (mm)	Largo (mm)	Largo útil (mm)	Uds.	Código	EAN	P.V.P. (€)
1,5	40	18	2	D-38299	0088381398787	1,25
2,0	49	24	2	D-38308	0088381398794	1,25
2,5	57	30	2	D-38314	0088381398800	1,20
3,0	61	33	2	D-38336	0088381398824	1,25
3,5	70	39	2	D-38358	0088381398848	1,25
4,0	75	43	2	D-38364	0088381398855	1,25
4,5	80	47	1	D-38386	0088381398879	0,90
5,0	86	52	1	D-38401	0088381398893	0,90
5,5	93	57	1	D-38417	0088381398909	0,90
6,0	93	57	1	D-38423	0088381398916	0,90
6,5	101	63	1	D-38439	0088381398923	1,25
7,0	109	69	1	D-38445	0088381398930	1,25
7,5	109	69	1	D-38451	0088381398947	1,25
8,0	117	75	1	D-38467	0088381398954	1,50
8,5	117	75	1	D-38473	0088381398961	1,50
9,0	125	81	1	D-38489	0088381398978	1,80
10,0	133	87	1	D-38495	0088381398985	2,15
11,0	142	94	1	D-38504	0088381398992	2,75
12,0	151	101	1	D-38510	0088381399005	3,30
13,0	151	101	1	D-38526	0088381399012	3,60

**Brocas para metal HSS-G DIN338**



- Brocas indicadas para el taladrado de acero con resistencia máxima de 900 N/mm<sup>2</sup>, metales de fundición, plásticos duros y metales no ferrosos.
- Ofrece una perforación más rápida y una vida útil superior.
- Espiral con dos salidas para una efectiva evacuación del material sobrante.
- Excelente calidad del acero con la que está realizada esta broca.
- Brocas para corte en metal con un ángulo en la punta de 135°.
- Biselado de la espiral para una corte más rápido y eficaz.
- Brocas de buena calidad para aplicaciones profesionales.

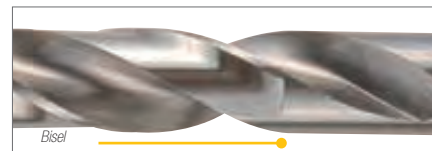

Ø (mm)	Largo (mm)	Largo útil (mm)	Uds.	Código	EAN	P.V.P. (€)
1,5	40	18	1	D-09656	0088381184922	0,90
2,0	49	24	1	D-09662	0088381184939	0,85
2,5	57	30	1	D-09678	0088381184946	0,90
3,0	61	33	1	D-09684	0088381184953	0,90
3,5	70	39	1	D-09690	0088381184960	1,20
4,0	75	43	1	D-09709	0088381184977	1,20
4,5	80	47	1	D-09715	0088381184984	1,30
5,0	86	52	1	D-09721	0088381184991	1,55
5,5	93	57	1	D-09737	0088381185004	1,75
6,0	93	57	1	D-09743	0088381185011	1,85
6,5	101	63	1	D-09759	0088381185028	2,05
7,0	109	69	1	D-09765	0088381185035	2,40
7,5	109	69	1	D-09771	0088381185042	2,65
8,0	117	75	1	D-09787	0088381185059	3,50

Ø (mm)	Largo (mm)	Largo útil (mm)	Uds.	Código	EAN	P.V.P. (€)
8,5	117	75	1	D-09793	0088381185066	3,20
9,0	125	81	1	D-09802	0088381185073	3,80
9,5	125	81	1	D-09818	0088381185080	4,10
10,0	133	87	1	D-09824	0088381185097	4,80
10,5	133	87	1	D-09830	0088381185103	6,10
11,0	142	94	1	D-09846	0088381185110	6,40
11,5	142	94	1	D-09852	0088381185127	7,00
12,0	151	101	1	D-09868	0088381185134	7,60
12,5	151	101	1	D-09874	0088381185141	8,10
13,0	151	101	1	D-09880	0088381185158	8,80
14	160	108	1	D-74893	0088381593786	20,00
15	169	114	1	D-74902	0088381593793	23,00
16	178	120	1	D-74918	0088381593809	26,00

**Brocas para metal HSS-CO DIN338 ★★★★★**

- Brocas para el taladrado de acero con resistencia máxima de 1.000 N/mm<sup>2</sup>, aceros tratados, aceros inoxidables y metales de fundición.
- Fabricadas con metal de alta calidad con un 5% de cobalto añadido.



Ø (mm)	Largo (mm)	Largo útil (mm)	Uds.	Código	EAN	P.V.P. (€)
1,5	40	18	1	D-17289	0088381195942	1,45
2,0	49	24	1	D-17295	0088381195959	1,45
2,5	57	30	1	D-17304	0088381195966	1,50
3,0	61	33	1	D-17310	0088381195973	1,55
3,2	65	36	1	D-17326	0088381195980	1,55
3,5	70	39	1	D-17332	0088381195997	1,55
4,0	75	43	1	D-17348	0088381196000	1,75
4,5	80	47	1	D-17354	0088381196017	2,05
5,0	86	52	1	D-17360	0088381196024	2,10
5,2	75	43	1	D-46682	0088381423205	2,75
5,5	93	57	1	D-17376	0088381196031	2,60
6,0	93	57	1	D-17382	0088381196048	2,75
6,5	101	63	1	D-17398	0088381196055	3,20
7,0	109	69	1	D-17407	0088381196062	3,70
7,5	109	69	1	D-17413	0088381196079	5,00
8,0	117	75	1	D-17429	0088381196086	6,10
8,5	117	75	1	D-17435	0088381196093	6,40
9,0	125	81	1	D-17441	0088381196109	6,40
9,5	125	81	1	D-17457	0088381196116	8,60
10,0	133	87	1	D-17463	0088381196123	9,70
10,5	133	87	1	D-17479	0088381196130	10,80
11,0	142	94	1	D-17485	0088381196147	11,10
11,5	142	94	1	D-17491	0088381196154	13,90
12,0	151	101	1	D-17500	0088381196161	14,00
12,5	151	101	1	D-17516	0088381196178	16,60
13,0	151	101	1	D-17522	0088381196185	17,80

**Brocas metal para SDS-PLUS ★★★★★**



- Nuevo sistema, sin necesidad de portabrocas

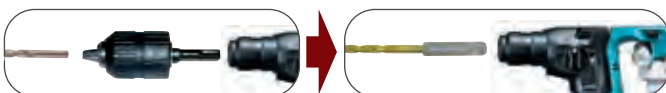

Ø (mm)	Largo (mm)	Largo útil (mm)	Uds.	Código	EAN	P.V.P. (€)
3	90	33	1	B-57401	0088381519014	3,50
3,5	100	39	1	B-57417	0088381519021	3,50
4	105	43	1	B-57423	0088381519038	4,10
4,5	110	47	1	B-57439	0088381519045	4,10
5	116	52	1	B-57445	0088381519052	5,00
5,5	123	5	1	B-57451	0088381519069	5,00
6	123	57	1	B-57467	0088381519076	5,00
6,5	131	63	1	B-57473	0088381519083	5,60

**Brocas para metal HSS-CO DIN338 ★★★★★**



**x5**

Ø (mm)	Largo (mm)	Largo útil (mm)	Uds.	Código	EAN	P.V.P. (€)
1,5	40	18	5	D-16617	0088381192002	3,50
1,75	46	20	5	D-17625	0088381196758	4,25
2	49	24	5	D-16623	0088381192019	4,25
2,5	57	30	5	D-16639	0088381192026	4,25
3	61	33	5	D-16645	0088381192033	5,75
3,2	65	36	5	D-16651	0088381194761	6,00
3,3	65	36	5	D-46632	0088381420600	6,25
3,5	70	39	5	D-16667	0088381192057	6,25
4	75	43	5	D-16673	0088381192064	6,75
4,2	75	43	5	D-34958	0088381367271	9,00
4,5	80	47	5	D-16689	0088381192071	9,00
5	86	52	5	D-16695	0088381192088	9,00
5,2	86	52	5	D-34992	0088381367417	10,25
5,5	93	57	5	D-16704	0088381192095	10,50
6	93	57	5	D-16710	0088381192101	11,50
6,5	101	63	5	D-16726	0088381192118	13,00
7,0	109	69	5	D-16732	0088381192125	15,50
7,5	109	69	5	D-16748	0088381192132	19,00
8,0	117	75	5	D-16754	0088381192149	23,00
8,5	117	75	5	D-16760	0088381192156	27,00
9,0	125	81	5	D-16776	0088381192163	31,00
9,5	125	81	5	D-16782	0088381192170	37,00
10,0	133	87	5	D-16798	0088381192187	40,00
10,5	133	87	5	D-16807	0088381192194	45,00
11,0	142	94	5	D-16813	0088381192200	52,00
11,5	142	94	5	D-16829	0088381192217	59,00
12	151	101	5	D-16835	0088381192224	64,00
12,5	151	101	5	D-16841	0088381192231	68,00
13	151	101	5	D-16857	0088381192248	75,00



**Brocas cónicas**

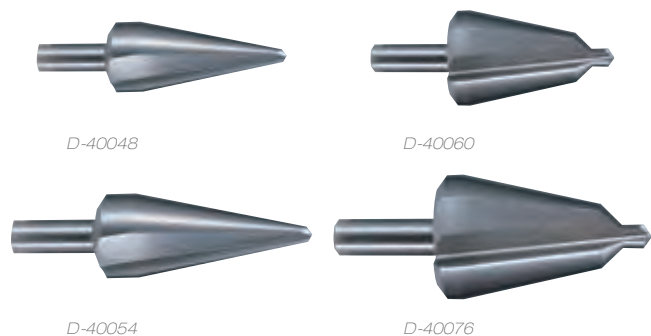

Ø (mm)	Flauta	Tipo	Uds.	Código	EAN	P.V.P. (€)
3-14	Recta	HSS	1	D-40048	0088381400244	19,10
4-20	Recta	HSS	1	D-40054	0088381400251	29,00
16-30,5	Recta	HSS	1	D-40060	0088381400268	54,00
24-40	Recta	HSS	1	D-40076	0088381400275	96,00

**Brocas cónicas escalonadas**

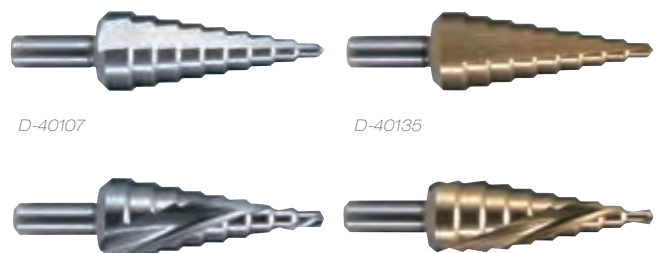

Ø (mm)	Flauta	Tipo	Uds.	Código	EAN	P.V.P. (€)
4-32	Recta	HSS	1	D-40107	0088381400305	73,00
4-32	Recta	HSS-TIN	1	D-40135	0088381400336	83,00
4-32	Espiral	HSS	1	D-40163	0088381400367	78,00
4-32	Espiral	HSS-TIN	1	D-40191	0088381400398	95,00

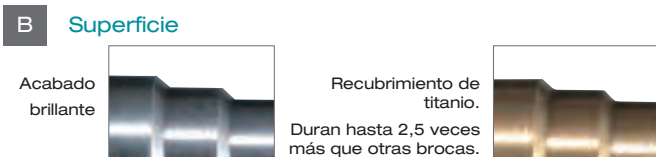
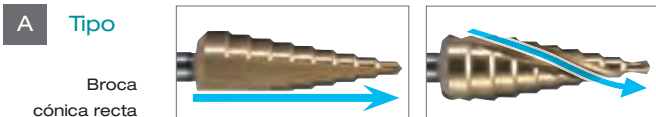



**Brocas cónicas escalonadas 1/4" hex. (9 niveles)**



- Permiten la perforación en 9 niveles a partir de una sola broca. Adecuado para ampliar orificios existentes.
- Diseñadas con acero HSS. Ideal para usar en metal y metales no ferrosos.
- Para taladros y atornilladores de impacto.



Ø (mm)	Flauta	Tipo	Uds.	Código	EAN	P.V.P. (€)	
4-20	Recta	HSS	1	D-40098	0088381400299	32,00	★★★
4-20	Recta	HSS-TIN	1	D-40129	0088381400329	33,00	★★★★
4-20	Espiral	HSS	1	D-40157	0088381400350	33,00	★★★
4-20	Espiral	HSS-TIN	1	D-40185	0088381400381	34,00	★★★★



**Estuche de brocas escalonadas TIN**



Longitud útil (mm)	Longitud (mm)	Uds.	Ø (mm)	Código	EAN	P.V.P. (€)
45 / 53 / 80 mm	65 / 75 / 102 mm	3	4-12 4-20 4-32	D-46573	0088381422918	120,00

**Brocas madera para SDS-PLUS**

★★★



Ø (mm)	Largo (mm)	Largo útil (mm)	Uds.	Código	EAN	P.V.P. (€)
4	105	43	1	B-57489	0088381519090	3,70
5	116	52	1	B-57495	0088381519106	3,80
6	123	57	1	B-57504	0088381519113	3,70
8	147	75	1	B-57510	0088381519120	4,40
10	163	87	1	B-57526	0088381519137	4,70

**Estuche brocas madera metal SDS-PLUS**



Descripción	Uds.	Código	EAN	P.V.P. (€)
Juego brocas SDS-PLUS madera y metal	1	B-57532	0088381519144	14,80

**Estuche brocas para metal SDS-PLUS HSS-TIN**



- Ideal para taladrar en materiales como acero, acero inoxidable, metal de fundición y metales no ferrosos.
- Para martillos SDS-PLUS. Angulo de punta 135°. Larga vida útil.

Longitud útil (mm)	Longitud (mm)	Uds.	Ø (mm)	Código	EAN	P.V.P. (€)
33 39 43 52 57	90 100 105 116 129	12	3 3,5 4 5 6	E-15132-12	0088381597753	175,00
33 39 43 52 57	90 100 105 116 129	1	3 3,5 4 5 6	E-15132	0088381597746	14,59



**Estuche de brocas para metal HSS-Co**



★★★★★

D-67561

D-75758

Ø (mm)	Contenido	Uds.	Código	EAN	P.V.P. (€)
de 1 a 10mm	19 piezas	1	D-67561	0088381549196	62,00
de 2 a 8mm	6 piezas	1	D-75758	0088381597241	15,50

**Estuche de brocas para metal M-Force**



★★★★★

Ø (mm)	Contenido	Uds.	Código	EAN	P.V.P. (€)
de 1 a 10mm	19 piezas	1	D-67583	0088381549219	66,00

**Estuche de brocas para metal HSS-G**



★★★

D-67549

D-75742

Ø (mm)	Contenido	Uds.	Código	EAN	P.V.P. (€)
de 1 a 10mm	19 piezas	1	D-67549	0088381549172	49,00
de 2 a 8mm	6 piezas	1	D-75742	0088381597234	10,70

**Estuches de brocas para metal HSS-R**



★

D-54081

D-54097

Ø (mm)	Contenido	Uds.	Código	EAN	P.V.P. (€)
de 1 a 10mm	19 piezas	1	D-54081	0088381450201	19,40
de 1 a 13mm	25 piezas	1	D-54097	0088381450218	32,00

**Estuche de brocas para metal HSS-TiN**



★★

Ø (mm)	Contenido	Uds.	Código	EAN	P.V.P. (€)
de 2 a 8mm	6 piezas	1	D-72833	0088381577342	6,40

**Estuche de brocas para metal HSS-TiN**



★★

Ø (mm)	Contenido	Uds.	Código	EAN	P.V.P. (€)
de 1 a 10mm	19 piezas	1	D-67527	0088381548243	25,00

**Estuche de brocas para ladrillo**



★★



★★★★



★★

D-72877

E-11536

D-73483

Ø (mm)	Contenido	Uds.	Código	EAN	P.V.P. (€)
4, 5, 6, 8 y 10 mm	5 piezas	1	D-72877	0088381577380	5,80
4, 5, 6, 8 y 10 mm	5 piezas	1	E-11536	0088381582827	8,20
4 - 5 - 5,5 - 6 - 6,5 - 7 - 8	12 piezas	1	D-73483	0088381584845	13,80



**Estuche de brocas para metal, ladrillo y madera**

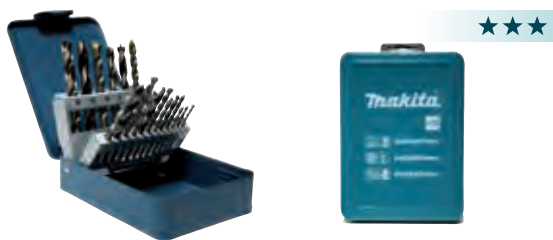

Contenido	Total	Uds.	Código	EAN	P.V.P. (€)
6 metal	18 piezas	1	D-46202	0088381411776	23,00
6 madera					
6 ladrillo					



Contenido	Total	Uds.	Código	EAN	P.V.P. (€)
3 metal	9 piezas	1	D-71962	0088381566490	9,50
3 madera					
3 ladrillo					

**Estuche de brocas para madera**



Ø (mm)	Contenido	Uds.	Código	EAN	P.V.P. (€)
de 4 a 10mm	5 piezas	1	D-72861	0088381577373	5,30

**Juego de brocas de pala para madera**



Ø (mm)	Contenido	Uds.	Código	EAN	P.V.P. (€)
de 12 a 32mm	8 piezas	1	E-08698	0088381579605	22,00

**Estuche de brocas 1/4" hexagonal**

- Madera
- Metal



Contenido	Total	Uds.	Código	EAN	P.V.P. (€)
3 metal	5 piezas	1	D-20769	0088381287760	12,90
2 madera					

- Madera
- Metal
- Ladrillo



Contenido	Total	Uds.	Código	EAN	P.V.P. (€)
2 metal	5 piezas	1	D-23759	0088381312844	10,20
2 madera					
1 ladrillo					

**Estuche de brocas Omnibohrer Multimaterial**



- Brocas para taladrar todo tipo de materiales ligeros como ladrillo, madera, aluminio, plástico y hormigón.
- Válidas para taladros de 2 modos. Taladro y taladro + percusión.
- Las brocas Omnibohrer de Makita son más duraderas que las brocas multimaterial de sus competidores.

Materia	Hormigón	Alegrjo	Ladrillo	Pizarra	Caliza	Madera	Madera + plástico	Plástico	Aluminio	Metal
Simbolo										
Modo										
valor	○	○	○	○	○	○	○	○	△	×

○ Excelente    △ Bueno    × No recomendable

Ø (mm)	Longitud (mm)	Uds.	Código	EAN	P.V.P. (€)
5	85	1	D-30477	0088381353335	7,10
6	100	1			
8	110	1			
10	150	1			
12	150	1			



**Estuche de puntas y brocas cilíndricas**

★★★

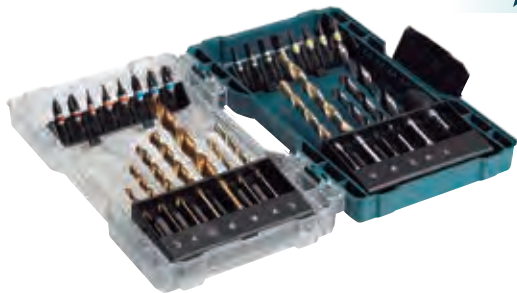

Contenido	Unds	Código	EAN	P.V.P. (€)
29 piezas	1	E-07054	0088381571258	26,00

**Estuche de puntas y brocas SDS-PLUS**

★★★



Contenido	Unds	Código	EAN	P.V.P. (€)
18 piezas	1	E-07026	0088381571227	31,00

**Set de puntas, vasos + avellanador**

★★



Contenido	Unds	Código	EAN	P.V.P. (€)
Puntas, avellanadores, portabrocas magnético, llaves de vaso...	1	D-73461	0088381584821	32,00

**Set de puntas + avellanador**

★★



Contenido	Unds.	Código	EAN	P.V.P. (€)
Puntas, avellanadores y portabrocas magnético...	1	D-73477	0088381584838	30,00

**Estuches de brocas y puntas**



- 7 puntas 1/4" hex: PH1, PH2, PH3, PZ1, PZ2, PZ3, SL5
- Portabrocas de 60mm.
- Brocas HSS-Tin (5, 6 y 8mm).
- Brocas madera (5, 6 y 8mm).
- Brocas hormigón (5, 6 y 8mm).

Contenido	Uds.	Código	EAN	P.V.P. (€)
17 piezas	1	D-74887	0088381592123	17,10



★★★

- Puntas 25 mm PH, PZ y T.
- Puntas 50 mm PH, PZ y T.
- Brocas pala 10 - 25 mm.
- Brocas HSS-R 1,5 - 6 mm.

Contenido	Uds.	Código	EAN	P.V.P. (€)
71 piezas	1	B-50295	0088381463317	41,00

**Set de brocas con avellanador 4pcs**









★★



Ø (mm)	Uds.	Código	EAN	P.V.P. (€)
6 - 8 - 10 - 12	1	D-73455	0088381584722	9,40

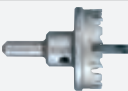

**Brocas de corona**

Aplicación	Aluminio 	Acero inoxidable 	PVC 	Acero 	Metales no ferrosos 	Madera 	Epoxy 
✓ Recomendado • Válido							
<b>Ezychange</b> 	✓	•	•	✓	✓	•	
BIM 	•		✓	✓	•	✓	
TCT 	•	✓	✓	✓	•		✓
Consejos	Usar aceite de corte	Bajas Rpm usar con aceite de corte		Usar aceite de corte	Usar aceite de corte		

**Brocas de corona Bi-Metálicas**



Aplicación:  
Para acero, hierro, metal, madera o plásticos.

Ø (mm)	Largo (mm)	Largo útil (mm)	Uds.	Código	EAN	P.V.P. (€)
14	50	38	1	D-35368	0088381369015	3,60
16	50	38	1	D-16994	0088381194792	3,70
17	50	38	1	D-35374	0088381369022	4,30
19	50	38	1	D-17005	0088381194808	4,20
20	50	38	1	D-17251	0088381195805	4,50
21	50	38	1	D-35380	0088381369039	4,80
22	50	38	1	D-17011	0088381194815	4,80
24	50	38	1	D-17027	0088381194822	5,50
25	50	38	1	D-17033	0088381194839	5,50
27	50	38	1	D-35396	0088381369046	5,50
29	50	38	1	D-17267	0088381195812	5,50
30	50	38	1	D-35405	0088381369053	5,70
32	44	38	1	D-17049	0088381194853	5,80
33	44	38	1	D-35411	0088381369060	6,00
35	44	38	1	D-17055	0088381194860	6,40
37	44	38	1	D-35427	0088381369077	6,40
38	44	38	1	D-17061	0088381194877	6,40
40	44	38	1	D-17273	0088381195829	6,70
41	44	38	1	D-35433	0088381369084	7,00
43	44	38	1	D-35449	0088381369091	7,30
44	44	38	1	D-17077	0088381194884	7,30
46	44	38	1	D-35455	0088381369107	7,90
48	44	38	1	D-35461	0088381369114	8,20
51	44	38	1	D-17083	0088381194891	8,50
52	44	38	1	D-35477	0088381369121	8,20
54	44	38	1	D-24876	0088381334778	8,20

Ø (mm)	Largo (mm)	Largo útil (mm)	Uds.	Código	EAN	P.V.P. (€)
56	44	38	1	D-35483	0088381369138	8,90
57	44	38	1	D-17099	0088381194907	8,90
59	44	38	1	D-35499	0088381369145	8,90
60	44	38	1	D-25688	0088381338516	8,90
64	44	38	1	D-30140	0088381351263	9,50
65	44	38	1	D-24882	0088381334785	9,50
67	44	38	1	D-35508	0088381369152	10,20
68	44	38	1	D-17108	0088381194914	10,20
70	44	38	1	D-25694	0088381338523	10,90
73	44	38	1	D-35514	0088381369169	11,20
76	44	38	1	D-17114	0088381194921	11,50
79	44	38	1	D-35520	0088381369176	11,50
83	44	38	1	D-17120	0088381194938	11,80
86	44	38	1	D-35536	0088381369183	11,80
89	44	38	1	D-35542	0088381369190	12,70
92	44	38	1	D-17136	0088381194945	12,70
95	44	38	1	D-35558	0088381369206	13,00
98	44	38	1	D-35564	0088381369213	13,30
102	44	38	1	D-35570	0088381369220	14,10
105	44	38	1	D-17142	0088381194952	14,60
108	44	38	1	D-35586	0088381369237	16,10
111	44	38	1	D-35592	0088381369244	16,60
114	44	38	1	D-35601	0088381369251	17,30
121	44	38	1	D-35617	0088381369268	17,90
127	44	38	1	D-17158	0088381194969	18,50
140	44	38	1	D-35623	0088381369275	20,00
152	44	38	1	D-17164	0088381194983	22,00

**Brocas de corona**

**Adaptador con broca de centrado para coronas Bi-Metálicas**



Ø (mm)	Tipo	Uds.	Código	EAN	P.V.P. (€)
14-29	10 Hex	1	D-17170	0088381194976	4,30
32-152	13 Hex	1	D-17186	0088381195003	7,90
14-29	SDS-PLUS	1	D-17603	0088381196727	6,40
32-76	SDS-PLUS	1	D-17619	0088381196734	10,40

**Broca de centrado para coronas Bi-Metálicas**



Ø (mm)	Longitud (mm)	Uds.	Código	EAN	P.V.P. (€)
6	71	1	D-17192	0088381194990	3,20



**Estuches de brocas de corona Bi-Metálicas**



D-47298

D-47117

Ø (mm)	Uso	Uds.	Código	EAN	P.V.P. (€)
19, 22, 25, 29, 35, 44, 51, 57, 68 y 75	Fontanería	1	D-47298	0088381424370	109,00
19, 22, 29, 38, 44 y 57	Fontanería	1	D-47117	0088381423731	48,00



D-47123

Ø (mm)	Uso	Uds.	Código	EAN	P.V.P. (€)
16, 20, 25, 32, 40 y 51	Electricidad	1	D-47123	0088381423748	41,00
20, 25, 32, 40, 51 y 65	Electricidad	1	D-47139	0088381423755	48,00



Ø (mm)	Uds.	Código	EAN	P.V.P. (€)
22, 29, 35, 44, 57, 64, 76, 92, 111, 127mm Inserción de 9,5 y 11mm. Adaptador y broca de centrado.	1	D-75764	0088381597692	140,00





**Brocas de corona Ezychange**



Brocas Bi-metálicas con cobalto válidas para: madera, metal, aluminio, acero inoxidable y plástico.



**ALTA CALIDAD con un 8% de COBALTO PARA UNA MAYOR DURACIÓN**

Ø (mm)	Largo (mm)	Largo útil (mm)	Uds.	Código	EAN	P.V.P. (€)
16	-	44	1	E-03632	0088381561877	9,50
17	46	40	1	B-31706	0088381419161	9,50
19	46	40	1	E-03654	0088381561891	9,75
20	46	40	1	E-03660	0088381561907	9,75
22	46	40	1	E-03676	0088381561914	11,00
25	46	40	1	E-03698	0088381561938	11,50
27	46	40	1	E-03707	0088381561945	11,50
29	46	40	1	E-03713	0088381561952	11,50
32	46	40	1	E-03735	0088381561976	11,50
37	46	40	1	E-03757	0088381561990	12,00
38	46	40	1	E-03763	0088381562003	12,50
40	46	40	1	E-03779	0088381562010	12,50
41	46	40	1	E-03785	0088381562027	12,75
44	46	40	1	E-03791	0088381562034	13,00
46	46	40	1	E-03800	0088381562041	13,50
51	46	40	1	E-03822	0088381562065	14,75
52	46	40	1	E-03838	0088381562072	16,50
56	46	40	1	E-03850	0088381562096	17,00

Ø (mm)	Largo (mm)	Largo útil (mm)	Uds.	Código	EAN	P.V.P. (€)
57	46	40	1	E-03866	0088381562102	17,75
60	46	40	1	E-03872	0088381562119	19,00
65	46	40	1	E-03894	0088381562133	19,00
67	46	40	1	E-14152	0083381592437	19,00
68	46	40	1	E-03903	0088381562140	20,75
73	46	40	1	E-03925	0088381562164	19,50
76	46	40	1	E-03931	0088381562171	19,50
79	46	40	1	E-03947	0088381562188	22,00
83	46	40	1	E-03953	0088381562195	22,00
86	46	40	1	E-03969	0088381562201	22,50
89	46	40	1	E-14168	0083381592444	25,00
95	46	40	1	E-03981	0088381562225	27,00
105	46	40	1	E-04008	0088381562249	32,00
111	46	40	1	E-04014	0088381562256	40,00
114	46	40	1	E-04020	0088381562263	40,00
121	46	40	1	E-04036	0088381562270	44,00
127	46	40	1	E-04042	0088381562287	50,00
133	46	40	1	E-14174	0088381592451	48,00
140	46	40	1	E-04058	0088381562294	49,00
152	46	40	1	E-04064	0088381562300	52,00

**Adaptadores para coronas Ezychange**

**Broca de centrado**



Longitud	Contenido	Uds.	Código	EAN	P.V.P. (€)
70 mm	Cilíndrico con broca de centrado	1	E-04070	0088381562317	27,00

Tipo	Uds.	Código	EAN	P.V.P. (€)
HSS	1	E-04086	0088381562324	8,00

**Estuches de brocas de corona Ezychange**

E-12304  
E-12310  
E-12326



E-14261



**Bi-metálicas 8% cobalto**

**TCT**

Ø (mm)	Material	Uds.	Código	EAN	P.V.P. (€)
19,22,29,38,44,57	Bimetálicas	6	E-12304	0088381585668	163,00
16,20,25,32,40,51		6	E-12310	0088381585675	150,00
20,25,32,40,51,65		6	E-12326	0088381585682	163,00
22,25,32,44,51,68, adaptador y broca de centrado	TCT	8	E-14261	0088381593632	260,00

**Brocas de corona multimaterial Ezychange**



E-06644

E-14261

Válidas para: madera, metal, aluminio, acero inoxidable, plástico, azulejo y fibra de vidrio.



Ø (mm)	Profundidad de corte(mm)	Uds.	Código	EAN	P.V.P. (€)
20	60	1	E-06644	0088381570367	24,00
22	60	1	E-06650	0088381570374	25,00
25	60	1	E-06666	0088381570381	25,00
32	60	1	E-06672	0088381570398	27,00
35	60	1	E-06688	0088381570404	27,00
38	60	1	E-06694	0088381570411	28,00
40	60	1	E-06703	0088381570428	29,00
44	60	1	E-06719	0088381570435	30,00
51	60	1	E-06725	0088381570442	33,00
54	60	1	E-06731	0088381570459	41,00
60	60	1	E-06747	0088381570466	43,00
64	60	1	E-06753	0088381570473	43,00
67	60	1	E-06769	0088381570480	44,00
68	60	1	E-06775	0088381570497	44,00
70	60	1	E-06781	0088381570503	45,00
73	60	1	E-06797	0088381570510	46,00
76	60	1	E-06806	0088381570527	46,00
83	60	1	E-06812	0088381570534	48,00
102	60	1	E-06828	0088381570541	72,00
127	60	1	E-06834	0088381570558	155,00



**Adaptadores para coronas Ezychange**



Longitud	Contenido	Uds.	Código	EAN	P.V.P. (€)
70 mm	Incluye broca de centrado	1	E-06959	0088381570701	36,00
150 mm	Adaptador	1	E-06878	0088381570596	32,00
300 mm	Adaptador	1	E-06884	0088381570602	35,00



**Broca de centrado**



Tipo	Uds.	Código	EAN	P.V.P. (€)
HSS-G	1	E-06840	0088381570565	10,70
HSS-CO	1	E-06856	0088381570572	15,00
TCT	1	E-06862	0088381570589	13,90



## Brocas de corona HM

★★★★★

Brocas de corona metal duro (alta durabilidad).

Con pastillas de metal duro, preparada para soportar altas temperaturas producidas por cortes profundos y continuos.

Para chapa de acero, acero inox, vigas de hierro (doble t), etc.

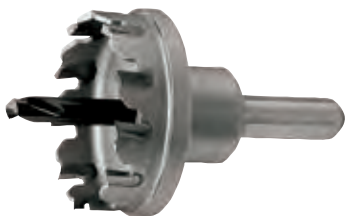

\* Para taladros superiores a 4mm de espesor se recomienda refrigerar la broca.



Ø (mm)	Inserción (mm)	Tipo	Uds.	Código	EAN	P.V.P. (€)
16	6	HM	1	B-00898	0088381114004	52,00
18	6	HM	1	B-00907	0088381114011	55,00
20	6	HM	1	B-00913	0088381114028	55,00
21	6	HM	1	B-00929	0088381114035	55,00
22	6	HM	1	B-00935	0088381114042	55,00
25	10	HM	1	B-00941	0088381114059	55,00
27	10	HM	1	B-00957	0088381114066	57,00
30	10	HM	1	B-00979	0088381114080	58,00
32	10	HM	1	B-00985	0088381114097	67,00
35	10	HM	1	B-00991	0088381114103	67,00
38	10	HM	1	B-01002	0088381114110	83,50
40	10	HM	1	B-01018	0088381114127	84,00
45	10	HM	1	B-01024	0088381114134	88,00
48	10	HM	1	B-01030	0088381114141	98,00
50	10	HM	1	B-01046	0088381114158	101,00
60	13	HM	1	B-01068	0088381114172	143,00
90	13	HM	1	B-01127	0088381114288	253,00

## Brocas de centrado para brocas HM



Ø (mm)	Tipo	Uso	Uds.	Código	EAN	P.V.P. (€)
6	HSS	Acero	1	B-01177	0088381114233	10,50
8	HSS	Acero	1	B-01183	0088381114240	11,00
6	HM	Resina, FRP...	1	B-01199	0088381114301	12,70
8	HM	Resina, FRP...	1	B-01208	0088381114318	15,40

## Batidores

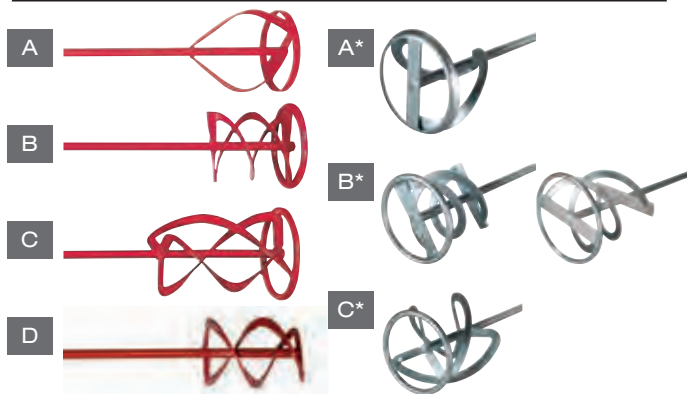

A	Para pinturas, lacas, yeso, revestimientos finos, etc.
B y D	Todos los materiales viscosos, conveniente para todos los tipos de mortero, yeso, resinas de epoxi llenadas por cuarzo, etc.
C	Para todos los materiales pegajosos y viscosos, por ejemplo pegamentos de azulejo, morteros, yesos, rellenos, etc.

Inser.	Ø (mm)	Long. (mm)	Tipo	Modelos	Uds.	Código	EAN	P.V.P. (€)	
8	80	400	A	DA6301 DS4010	1	P-02331	0088381918527	15,40	
10	90	400	D		1	P-02347	0088381918534	14,90	
8	100	590	C	UT1200 UT1400 UT1401 UT1600	1	P-02353	0088381918541	34,00	
M14	90	590	D		1	P-22028	0088381949088	27,00	
M14	120	590	A		1	P-22012	0088381949071	26,00	
M14	140	590	B		1	P-22040	0088381949101	33,00	
M14	120	590	C		1	P-22056	0088381949118	39,00	
M14	120	600	A*		1	D-73508	0088381584869	17,30	
M14	120	600	B*		1	D-73514	0088381584876	18,60	
M14	120	600	C*		1	D-73520	0088381584883	18,60	
3/8" hex					DA6301 DS4010		D-73536	0088381584890	11,80
10	120	600	B*			1	D-73542	0088381584906	11,10

## Adaptadores para batidores



Modo de empleo: Para utilizar batidor de inserción M14 en un taladro, es necesario desmontar el portabrocas, en su lugar colocar el adaptador y en el otro extremo insertar el batidor que más convenga para el tipo de trabajo.

Ø (mm)	Inserción	Modelo	Uds.	Código	EAN	P.V.P. (€)
1/2"	M14	6013B/DP4002	1	P-22062	0088381949125	11,00
5/8"	M14	DA6301	1	P-02325	0088381918510	11,00

## Disco mezclador (sin varilla)



Ø (mm)	Inserción	Modelo	Uds.	Código	EAN	P.V.P. (€)
165 mm	M8	DUT130	1	A-43692	0088381198707	16,00

## Varilla para mezclador inox. A-43692

Ø (mm)	Inserción	Modelo	Uds.	Código	EAN	P.V.P. (€)
1/2"	M14	6013B/DP4002	1	168349-5	0088381160261	26,00



**Puntas para atornillar Impact Black**



**Estuches de puntas y llaves de vaso Impact Black**



★★★

Punta	Uds.	Código	EAN	P.V.P. (€)
35 Piezas: PH 3xPH2 PH3 x 25mm PH1 2xPH2 PH3 x 50mm PZ1 3xPZ2 PZ3 x 25mm PZ1 2xPZ2 PZ3 x 50mm T15 2xT20 2xT25 T30 x 25mm T15 T20 2xT25 T30 x 50mm SL5,5 x 50mm Llaves de vaso: 6,8,10,13mm Portapuntas magnético 60mm	1	B-66880	0088381540018	43,00



★★★

Punta	Uds.	Código	EAN	P.V.P. (€)
33 Piezas: PH 25 mm PH1, 3 x PH2, PH3 PZ 25 mm PZ1, 3 x PZ2, PZ3 T 25 mm T15, 2 x T20, 2x T25, T30 PH 50 mm PH2 PZ 50 mm PZ2 T 50 mm T15, T20, T25, T30 Llaves de vaso de 50 mm: 6,8,10mm Llaves de vaso de 60 mm Llaves de vaso de 80 mm Brocas HSS-G: 2,5, 3, 3,5, 4, 4,5, 5 mm	1	B-66896	0088381540025	43



★★★

Punta	Uds.	Código	EAN	P.V.P. (€)
Llaves de vaso impact black 1/4", 6 pcs 6, 7, 8, 10, 12 y 13 mm	1	E-15768	0088381599818	19,30



★★★

Punta	Uds.	Código	EAN	P.V.P. (€)
7 puntas de 25 mm: PH1, PH2, PH3, PZ1, PZ2, PZ3, T15, T20, T25, T30	1	E-11994	0088381589468	8,80



★★★

Punta	Uds.	Código	EAN	P.V.P. (€)
10 puntas de 50 mm: PH1, PH2, PH3, PZ1, PZ2, PZ3, T15, T20, T25, T30	1	E-12011	0088381589482	14,90



★★★

Punta	Uds.	Código	EAN	P.V.P. (€)
10 puntas de 25 mm: PH2 / PZ2 / T15 / T20 x 2 / T25 x 2 / T30 x 2 portapuntas magnético (MZ)	1	E-15811	0088381790093	11,25



★★★

Punta	Uds.	Código	EAN	P.V.P. (€)
10 puntas de 25 mm: PH1 - 3 / PZ1 - 3 / T15 / T20 / T30	1	E-12005	0088381589475	12,50



**Expositor de cartón Impact Black (10unds)**

★★★



Contenido	Pcs.	Uds.	Código	EAN	P.V.P. (€)
Set de puntas	33	10	E-12441-10	0088381587792	243,00

**Expositor de cartón Impact Black (12unds)**

★★★



Contenido	Pcs.	Uds.	Código	EAN	P.V.P. (€)
25 puntas: PH2-25mm	25	12	E-12360-12	0088381586573	177,00
25 puntas: PZ2-25mm	25	12	E-12376-12	0088381586597	177,00
10 puntas: PH2-50mm	10	12	E-12407-12	0088381586658	133,00
10 puntas: PZ2-50mm	10	12	E-12413-12	0088381586726	133,00

**Portapuntas magnético Impact Black**

★★★



E-24125



E-24131



E-24147

N  
N  
N

Descripción	Uds.	Código	EAN	P.V.P. (€)
Portapuntas magnético 76 mm	1	E-24125	0197050355539	7
Portapuntas magnético 125 mm	1	E-24131	197050355546	11
Portapuntas magnético 304 mm	1	E-24147	197050355553	13

**Guía de atornillado Impact Black**

★★★



Descripción	Uds.	Código	EAN	P.V.P. (€)
Guía de atornillado 80 mm	1	B-66818	0088381539944	6,00

**Portapuntas magnético Impact Black**

★★★



B-66793



B-66802

Descripción	Uds.	Código	EAN	P.V.P. (€)
Portapuntas magnético 60 mm	1	B-66793	0088381539920	4,90
	1	B-66802	0088381539937	4,80

**Llaves de vaso Impact Black**

★★★



Descripción	Medidas (mm)	Uds.	Código	EAN	P.V.P. (€)
Llave vaso magnética	6x50	1	B-66824	0088381539951	3,30
Llave vaso magnética	8x50	1	B-66830	0088381539968	3,40
Llave vaso magnética	10x50	1	B-66846	0088381539975	3,30
Llave vaso magnética	13x50	1	B-66852	0088381539982	3,40

**Puntas serie Impact Black**



★★★

**Cambios de inserción Impact Black**



B-66868

B-66874

★★★

Descripción	Uds.	Código	EAN	P.V.P. (€)
Portapuntas magnético 60 mm 1/4" - 3/8"	1	B-66868	0088381539999	2,40
Portapuntas magnético 60 mm 1/4" - 1/2"	1	B-66874	0088381540001	2,95

Descripción	Longitud (mm)	Uds.	Código	EAN	P.V.P. (€)
PH1	25	2	B-63600	0088381532877	1,75
PH2	25	2	B-63616	0088381532884	1,75
PH3	25	2	B-63622	0088381532891	1,75
PH1	50	2	B-63719	0088381532983	2,60
PH2	50	2	B-63725	0088381532990	2,60
PH3	50	2	B-63731	0088381533003	2,60
PZ1	25	2	B-63638	0088381532907	1,75
PZ2	25	2	B-63644	0088381532914	1,75
PZ3	25	2	B-63650	0088381532921	1,75
PZ1	50	2	B-63747	0088381533010	2,60
PZ2	50	2	B-63753	0088381533027	2,60
PZ3	50	2	B-63769	0088381533034	2,60
T15	25	2	B-63666	0088381532938	1,75
T20	25	2	B-63672	0088381532945	1,75
T25	25	2	B-63688	0088381532952	1,75
T30	25	2	B-63694	0088381532969	1,75
T40	25	2	B-63703	0088381532976	1,75
T15	50	2	B-63775	0088381533041	2,60
T20	50	2	B-63781	0088381533058	2,60
T25	50	2	B-63797	0088381533065	2,60
T30	50	2	B-63806	0088381533072	2,60
T40	50	2	B-63812	0088381533089	2,60
PH2	25	25	E-12360	0088381586566	14,60
PH2	50	10	E-12407	0088381586641	10,50
PZ2	25	25	E-12376	0088381586580	14,60
PZ2	50	10	E-12413	0088381586719	10,50
T20	25	25	E-12382	0088381586603	14,60
T25	25	25	E-12398	0088381586627	14,60
T30	25	25	E-12653	0088381588324	14,60
T40	25	25	E-12669	0088381588348	14,60
T20	50	10	E-12429	0088381586665	10,50
T25	50	10	E-12435	0088381586689	10,50
T30	50	10	E-12675	0088381588362	10,50
T40	50	10	E-12681	0088381588386	10,50





## Portapuntas

### Rapidfix

★★★★

- Sujeción segura y sin holgura del portapuntas.
- El mecanismo de sujeción especial de este portapuntas permite retener todo tipo de puntas con acople hexagonal de 1/4".
- Manejo con una mano, para un cambio rápido de la punta.
- Estilizado cuerpo de metal con casquillo funcional ergonómico. Aguanta las más duras condiciones de atornillado y taladrado.
- Recomendado para atornilladores de impacto.



Tipo	Long. (mm)	Inserción	Uds.	Código	EAN	P.V.P. (€)
Click	60	1/4"	1	P-54075	0088381984584	19,30

### Clickfix

★★★★

- Magnético.
- Robusto cuerpo en aluminio.
- Sujeción segura de las puntas o brocas.
- Manejo con una sola mano.
- Casquillo de guía giratorio para un atornillado más fácil y seguro.



Tipo	Long. (mm)	Inserción	Uds.	Código	EAN	P.V.P. (€)
Imantado	60	1/4"	1	P-53263	0088381983778	18,70

### Porta puntas 1/4" hex. 80mm para martillos SDS-PLUS

★★★



Longitud (mm)	Inserción	Uds.	Código	EAN	P.V.P. (€)
80	SDS - PLUS	1	B-57548	0088381519151	6,60

### Estándar

★★

- Magnético.
- Robusto cuerpo metálico.
- Sujeción segura de las puntas.



Tipo	Long. (mm)	Inserción	Uds.	Código	EAN	P.V.P. (€)
Imantado	60	1/4"	1	784811-8	0088381430807	4,00
	75	1/4"	1	784801-1	0088381114738	3,40

### Portapuntas flexible

★★★

- Portapuntas magnético.
- Ideales para realizar atornillados en esquinas o bordes de difícil acceso.
- El eje se puede doblar para conseguir llegar a lugares estrechos donde es complicado el atornillado.



Tipo	Long. (mm)	Inserción	Uds.	Código	EAN	P.V.P. (€)
Magnético	200	1/4"	1	B-29072	0088381415507	7,30
Magnético	300	1/4"	1	B-29094	0088381415521	9,10

- Especial impacto.

★★★★★



Tipo	Long. (mm)	Inserción	Uds.	Código	EAN	P.V.P. (€)
Magnético	300	1/4"	1	B-51867	0088381466806	36,00

**Vasos especiales colocación en varilla roscada**

★★★

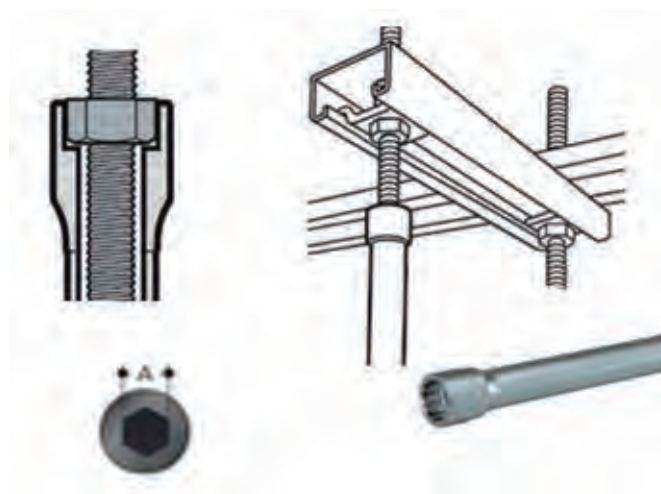

Tornillo	Ø (mm)	Long. (mm)	Inserción	Uds.	Código	EAN	P.V.P. (€)
M6	10	150	1/4"	1	B-52532	0088381469111	27,00
	10	300	1/4"	1	B-52548	0088381469128	29,00
	10	500	1/4"	1	B-52554	0088381469135	49,00
M8	13	150	1/4"	1	B-52582	0088381469166	27,00
	13	300	1/4"	1	B-52598	0088381469173	29,00
	13	500	1/4"	1	B-52607	0088381469180	49,00
M10	17	150	1/4"	1	B-52635	0088381469210	29,00
	17	300	1/4"	1	B-52641	0088381469227	32,00
	17	500	1/4"	1	B-52657	0088381469234	51,00



**Llaves de vaso 1/4" magnéticos**

★★



Tornillo	Ø (mm)	Longitud (mm)	Uds.	Código	EAN	P.V.P. (€)
M3	5,5	50	1	B-38685	0088381433327	2,40
M3,5	6	50	1	B-38691	0088381433334	2,40
M4	7	50	1	B-38700	0088381433341	4,80
M5	8	50	1	B-38716	0088381433358	2,45
M6	10	50	1	B-38722	0088381433365	2,40
M8	12	50	1	B-38738	0088381433372	2,45
M8	13	50	1	B-38744	0088381433389	4,90
M10	17	50	1	B-38750	0088381433396	4,90
Para modelo FS2500 y FS2700						
M6	10	65	1	784806-1	0088381114585	22,00
1/2"	12,7	65	1	784805-3	0088381102735	24,00



**Llaves de vaso para colocación de varilla roscada**

★★★★★



Ø (mm)	Inserción	Uds.	Código	EAN	P.V.P. (€)
6	1/4"	1	B-42961	0088381441995	19,30
8	1/4"	1	B-42977	0088381442008	20,00
10	1/4"	1	B-42983	0088381442015	20,00

**Adaptador cambio de inserción**

★★



Descripción	Uds.	Código	EAN	P.V.P. (€)
Adaptador 1/4 a 3/8"50mm.	1	B-54667	0088381478380	2,90
Adaptador 1/4 a 1/2"50mm.	1	B-54673	0088381478397	3,80
Adaptador 1/4 a 3/8"150mm.	1	B-57738	0088381521994	9,30
Adaptador 1/4 a 1/2"150mm.	1	B-57744	0088381522007	11,40

**Adaptador cambio de inserción**

★★★



Descripción	Uds.	Código	EAN	P.V.P. (€)
Adaptador 1/4 a 1/4" 50mm.	1	D-74740	0088381589512	1,65

**Set de llaves de vaso hexagonal**

★★



Tamaño (mm)	Longitud (mm)	Uds.	Código	EAN	P.V.P. (€)
8 - 10 - 12 - 13	48	1	B-57554	0088381519168	6,70

**Guía de atornillado**

★★



B-52934

B-48773



Contenido	Longitud (mm)	Uds.	Código	EAN	P.V.P. (€)
Guía 80 mm	80	1	B-48751	0088381455756	5,10
Guía 120 mm	120	1	B-52934	0088381471312	5,80
Guía 120 mm	120	1	B-48767	0088381455763	6,40
Guía 80 mm 5 PH2 5 PZ2 5 T20 5 T25 5 T30	80	1	B-48773	0088381455770	17,50
Guía 120 mm 5 PH2 5 PZ2 5 T20 5 T25 5 T30	120	1	B-48789	0088381455787	17,50



**Set herramientas manuales (87 pcs)**

★★★

- Llave de carraca 1/2".
- Llave de carraca con doble inserción 1/4" y 3/8".
- Llave portapuntas manual 152 mm.
- Llave manual ajustable 150 mm.
- Alicates 150 mm.
- Llaves combinadas manuales 10 - 12 - 13 - 14 - 17 mm.
- Set de llaves allen 1,5 - 2 - 2,5 - 3 - 4 - 5 - 6 - 8 mm.
- Destornilladores manuales PH1, PH2, PZ2 y plano 1.0 - 6.0.
- Desatornillador para carburadores.
- Vasos 1/4": 5 - 6 - 7 - 8 - 9 - 10 - 11 - 12 - 13 mm.
- Vasos largos 1/2": 8 - 10 - 12 - 13 - 15 - 17 - 19 mm.
- Portapuntas y portapuntas magnético.
- Puntas PH, PZ, T y TH.
- Adaptador 1/4".



Contenido	Unds	Código	EAN	P.V.P. (€)
87 piezas	1	E-08458	0088381575638	163,00

**Set herramientas manuales (76 pcs)**

★★★

- Llave de carraca 3/8"
- Destornillador para puntas 1/4
- Cúter
- Desatornillador para vasos 1/4"
- Martillo 180mm
- Alicates 150 mm.
- Alicates de punta de aguja 150mm
- Vasos largos 3/8": 8mm - 9mm - 10mm - 11mm - 12mm - 13mm - 14mm - 15mm - 16mm - 17mm - 18mm - 19mm - 20mm - 21mm
- Vasos 1/4": 4 - 5 - 6 - 7 - 8
- Portapuntas magnético.
- Set de llaves de vaso 1/4": 5 - 6 - 7 - 8 - 9 - 10 - 11
- Adaptador de vaso 1/2" 1/4" - 3/8"
- Puntas 25mm 1/4": PH1 - PH2 - PH3 - T8 - T9 - T10 - T15 - T20 - T25 - T27 - T30 - T40 - T8H - T10H - T15H - T20H - T25H - T27H - T30H - T40H - SL 0,5X3,0 - SL 0,8X4,0 - SL 0,8X5,0 - SL 1,0X5,5 - SL 1,0X6,0
- Extensores para vasos 3/8" 75mm 150mm
- Rótulas 1/4" y 3/8".



Contenido	Unds	Código	EAN	P.V.P. (€)
76 piezas	1	E-10899	0088381581493	109,00

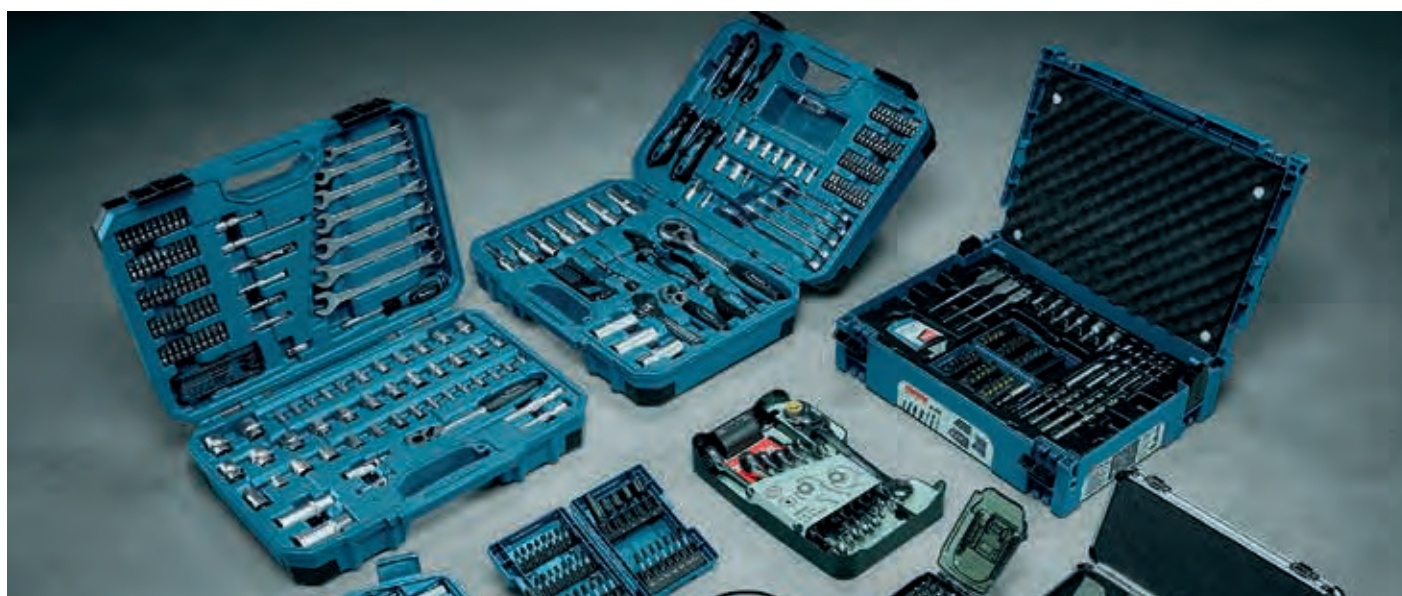

### Estuche de puntas y vasos (30 pcs)

- Puntas 25 mm PH, PZ, T, Hex y planas. ★★
- Puntas 50 mm PH, PZ, T y planas.
- Portapuntas magnético.
- Adaptador para vasos 3/8".
- Vasos 3/8" 63 mm: 17 y 19 mm.
- Vasos 1/4" hex. magnéticos 8 y 10 mm.



Contenido	Unds	Código	EAN	P.V.P. (€)
30 piezas	1	E-07060	0088381571265	33,00

### Set de llaves, puntas y vasos 221pcs

- Llave de carraca 1/4" y 1/2". ★★★
- Llave manual 1/4".
- Extensiones para vasos 1/4" y para vasos 1/2".
- Adaptador 3 posiciones de 1/2" a 3/8".
- Rótulas de 1/4" y 1/2".
- Vasos 1/4" de 25 mm: 4, 4.5, 5, 5.5, 6, 7, 8, 9, 10, 11, 12, 13 y 14.
- Vasos 1/2" de 38 mm: 15, 16, 17, 19, 20, 21, 22, 24, 27, 30 y 32.
- Vasos estrella 1/2" de 38 mm: E10, E12, E14, E16, E18, E20 y E24.
- Vasos 1/4" hex. de 38 mm: 5, 5.5, 6, 7, 8, 9, 10, 11, 12 y 13.
- Llaves fijas combinadas de 8 a 19 mm.
- Set de llaves allen de 1.5 a 8 mm.
- Mango destornillador.
- Puntas planas, PH, PZ, T, Hex...
- Portapuntas magnético.



Contenido	Unds	Código	EAN	P.V.P. (€)
221 piezas	1	E-10883	0088381581486	215,00

### Maletín de herramienta manual 120 piezas

- Llave de carraca 3/8".
- Vasos 1/4" 25mm: 4, 4.5, 5, 5.5, 6, 7, 8, 9, 10, 11, 12, 13 y 14mm.
- Vasos 3/8" 28 y 30mm: 8, 9, 10, 11, 12, 13, 14, 15, 16, 17, 18, 19, 20 y 21mm.
- Vasos estrella 1/4" 25mm: E4, E5, E6, E7 y E8.
- Vasos estrella 3/8" 28 y 30mm: E10, E11, E12, E14, E16 y E18.
- Vasos largos 1/2" de 16 y 21mm.
- Adaptadores 3/8", 1/4" y 1/2".
- Extensiones para vasos 1/4" y para vasos 3/8".
- Rótulas de 1/4" y 3/8".
- Llaves fijas combinadas de 8, 10, 11, 12, 13, 14 y 15mm.
- Llave manual 1/4".
- Portapuntas magnético y guía de atornillado.
- Puntas planas, PH, PZ, T, Hex...



Contenido	Unds	Código	EAN	P.V.P. (€)
120 piezas	1	E-06616	0088381570251	138,00

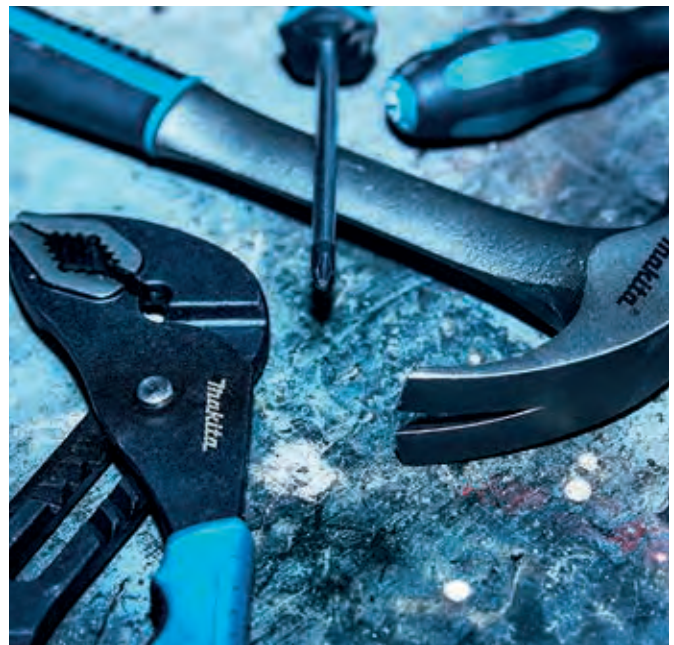



**Llaves de vaso CR-MO**

★★★

(sin arandela ni bulón)



Inserción	Métrica	Ø int (mm)	Ø ext (mm)	Long. (mm)	Código	EAN	P.V.P. (€)
3/8"	-	6	11	28	B-39883	0088381436595	3,80
3/8"	-	7	12	28	B-39899	0088381436601	3,80
3/8"	-	8	13	28	B-39908	0088381436618	3,80
3/8"	-	9	14	28	B-39914	0088381436625	3,80
3/8"	-	10	15	28	B-39920	0088381436632	3,80
3/8"	-	11	18	28	B-39936	0088381436649	3,80
3/8"	M7	12	18	28	B-39942	0088381436656	3,70
3/8"	M8	14	20	28	B-39964	0088381436670	4,40
3/8"	-	15	22	28	B-39970	0088381436687	4,70
3/8"	-	16	24	28	B-39986	0088381436694	4,70
3/8"	M10	17	24	28	B-39992	0088381436700	4,70
3/8"	-	18	28	28	B-40004	0088381436717	5,20

**Llaves de vaso Impact Black**

★★★

(sin arandela ni bulón)



Inserción	Ø int. (mm)	Long. (mm)	Código	EAN	P.V.P. (€)
<b>N</b> 1/2"	10	38	E-16069	0088381790710	4,25
<b>N</b> 1/2"	12	38	E-16081	0088381790734	4,25
<b>N</b> 1/2"	13	38	E-16097	0088381790741	4,25
<b>N</b> 1/2"	14	38	E-16106	0088381790758	4,25
<b>N</b> 1/2"	16	38	E-16128	0088381790772	4,75
<b>N</b> 1/2"	17	38	E-16134	0088381790789	4,75
<b>N</b> 1/2"	19	38	E-16156	0088381790802	4,75
<b>N</b> 1/2"	21	38	E-16178	0088381790826	5,25
<b>N</b> 1/2"	23	38	E-16190	0088381790840	7,50
<b>N</b> 1/2"	24	38	E-16209	0088381790857	7,50
<b>N</b> 1/2"	27	42	E-16215	0088381790864	8,00
<b>N</b> 1/2"	30	44	E-16221	0088381790871	9,00
<b>N</b> 1/2"	32	44	E-16237	0088381790888	9,50
<b>N</b> 1/2"	13	81	E-16449	0088381791090	5,25
<b>N</b> 1/2"	17	81	E-16477	0088381791120	6,50
<b>N</b> 1/2"	19	81	E-16499	0088381791144	7,25
<b>N</b> 1/2"	21	81	E-16508	0088381791151	8,25

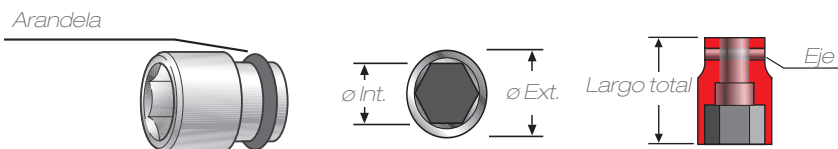

**Arandela de goma - Bulón**



Tipo	Código	EAN	P.V.P. (€)
A	213397-0	-	1,20
B	213398-8	0088381155496	1,20
C	213399-6	0088381495240	1,20
D	213461-7	3240890114174	1,20
E	213514-2	0088381495264	1,20
F	213570-2	0088381200028	1,60

Tipo	Código	EAN	P.V.P. (€)
1	268056-1		1,20
2	268057-9	0088381162708	1,20
3	256283-2		1,20
4	256282-4	0088381495431	1,20
5	256284-0	0088381200035	2,10



**Llaves de vaso (incluye arandela y bulón) sin clip**



★★★



Tipo	Inserción	Ø int (mm)	Long. (mm)	Código	EAN	P.V.P. (€)
A	3/4"	17	51	E-22224	0088381717830	20,00
	3/4"	19	51	E-22230	0088381717847	20,00
	3/4"	19	90	E-22333	0088381717946	29,00
	3/4"	21	51	E-22246	0088381717854	20,00
	3/4"	21	90	E-22349	0088381717953	29,00
	3/4"	22	51	E-22252	0088381717861	20,00
	3/4"	24	51	E-22268	0088381717878	20,00
	3/4"	24	90	E-22355	0088381717960	29,00
	3/4"	26	53	E-22274	0088381717885	20,50
	3/4"	27	53	E-22280	0088381717892	20,50
	3/4"	27	90	E-22361	0088381717977	30,50
	3/4"	30	53	E-22296	0088381717908	21,00
	3/4"	30	90	E-22377	0088381717984	33,00
	3/4"	32	57	E-22305	0088381717915	21,00
	3/4"	32	90	E-22383	0088381717991	33,50
	3/4"	35	57	E-22311	0088381717922	24,00
3/4"	36	57	E-22327	0088381717939	24,00	
3/4"	36	90	E-22399	0088381718004	37,00	
B	1"	41	80	E-22420	0088381718035	52,00

N  
N  
N  
N  
N  
N  
N  
N  
N  
N  
N  
N  
N  
N  
N  
N  
N  
N  
N  
N  
N

**Arandela de goma - Bulón**

Tipo	Descripción	Código	EAN	P.V.P. (€)
A	Junta torica llave de vaso 3/4"	E-22408	0088381718011	1,25
	Bulón llave de vaso 3/4"	E-22414	0088381718028	1,25
B	Junta torica llave de vaso 1"	E-22436	0088381718042	1,25
	Bulón llave de vaso 1"	E-22442	0088381718059	1,25

**Estuche de llaves de vaso 9 piezas**

★★★

- Estuche de 9 piezas con espuma interior para una buena conservación de los vasos.
- Cada vaso monta su propia goma y bulón, para una sujeción perfecta a la máquina.
- Información de la composición: CR-MO (Cromo-molibdeno)



Inserción	Ø int. (mm)	Ø ext. (mm)	Long. (mm)	Código	EAN	P.V.P. (€)
1/2"	8	15	38	E-16564	0088381791212	58,00
1/2"	10	17,5	38			
1/2"	13	20	38			
1/2"	16	24	38			
1/2"	17	26	38			
1/2"	18	28	38			
1/2"	19	28	38			
1/2"	21	30	38			
1/2"	24	34	38			

**Juego de vasos de impacto 12 piezas**



Inserción	Ø int. (mm)	Long. (mm)	Código	EAN	P.V.P. (€)
1/4"	6	23	E-12289	0088381589529	14,90
	7	23			
	8	23			
	10	23			
	11	23			
	12	23			
	13	23			

## Gratas para taladros

### Cepillos oblicuos de nylon

★★

- Ideal para la limpieza en superficies estrechas, bordes o ranuras. Eliminación de óxido, esmaltes, barnices, etc. Tanto en metales, como en plásticos o maderas.



Ø (mm)	Inserción (mm)	Grano	Espesor (mm)	Tipo	Unds.	Código	EAN	P.V.P. (€)
38	6	80	1,4	Nylon	1	D-45565	0088381408776	4,10
50	6	80	1,4	Nylon	1	D-45571	0088381408783	5,00
63	6	80	1,4	Nylon	1	D-45587	0088381408790	5,20
75	6	80	1,4	Nylon	1	D-45593	0088381408806	7,00
100	6	80	1,4	Nylon	1	D-45602	0088381408813	8,10
38	6	240	0,7	Nylon	1	D-45618	0088381408820	4,10
50	6	240	0,7	Nylon	1	D-45624	0088381408837	5,00
63	6	240	0,7	Nylon	1	D-45630	0088381408844	5,20
75	6	240	0,7	Nylon	1	D-45646	0088381408851	7,00
100	6	240	0,7	Nylon	1	D-45652	0088381408868	8,10

### Cepillos oblicuos de alambre

★★

- Muy eficaz para eliminar las rebabas y el óxido en trabajos finos.
- Alambres ondulados para que la superficie terminada quede mucho más suave.



Ø (mm)	Inserción (mm)	Grano	Espesor (mm)	Tipo	Unds.	Código	EAN	P.V.P. (€)
38	6	-	5	Alambre	1	D-39958	0088381400077	2,05
50	6	-	7	Alambre	1	D-39964	0088381400084	2,35
63	6	-	9	Alambre	1	D-39970	0088381400091	2,60
75	6	-	10	Alambre	1	D-39986	0088381400107	2,95
100	6	-	12	Alambre	1	D-39992	0088381400114	3,20

### Cepillos oblicuos de alambre latonado

★★

- Muy eficaz para cepillar ranuras, especialmente en madera.



D-73651

D-73673

D-73695

Ø (mm)	Inserción (mm)	Grano	Espesor (mm)	Tipo	Unds.	Código	EAN	P.V.P. (€)
38	6	-	5	Latonado	1	D-73651	0088381586184	1,55
50	6	-	7	Latonado	1	D-73667	0088381586191	1,65
63	6	-	9	Latonado	1	D-73673	0088381586207	1,85
75	6	-	10	Latonado	1	D-73689	0088381586214	2,00
100	6	-	12	Latonado	1	D-73695	0088381586221	2,25

### Cepillos oblicuos de alambre trenzado

★★

- Ideal para superficies estrechas y ranuras principalmente de metal.



D-73813

Ø (mm)	Inserción (mm)	Grano	Espesor (mm)	Tipo	Unds.	Código	EAN	P.V.P. (€)
75	6	-	-	Trenzada	1	D-73813	0088381586443	4,80
100	6	-	-	Trenzada	1	D-73829	0088381586450	5,00

### Set de gratas de nylon para taladros

**GRUESA (rojo) y FINA (azul)**

★★

- Contiene copa ondulada 50 mm, cepillo oblicuo 50 mm y cepillo de acabado 24 mm.



Ø (mm)	Inserción (mm)	Grano	Espesor (mm)	Tipo	Unds.	Código	EAN	P.V.P. (€)
50	6	80	1,4	Nylon	1	D-70742	0088381556033	11,10
50	6	80	1,4	Nylon	1			
24	6	80	1,4	Nylon	1			

Ø (mm)	Inserción (mm)	Grano	Espesor (mm)	Tipo	Unds.	Código	EAN	P.V.P. (€)
50	6	240	0,7	Nylon	1	D-70758	0088381556040	11,10
50	6	240	0,7	Nylon	1			
24	6	240	0,7	Nylon	1			

**Gratas para amoladoras de acero**

**Copa ondulada de alambre** ★★

- Para superficies planas o rugosas. Alambres ondulados para que la superficie terminada quede mucho más suave.



Ø (mm)	Inserción (mm)	Espesor (mm)	Tipo	Unds.	Código	EAN	P.V.P. (€)
60	M14	0,3	Acero	1	D-24072	0088381313674	4,10
75	M14	0,3	Acero	1	D-24094	0088381313698	4,70
100	M14	0,3	Acero	1	D-29284	0088381345835	6,70
60	M14	0,3	Acero latonado	1	D-39746	0088381399869	4,10
75	M14	0,3	Acero latonado	1	D-39768	0088381399883	4,70
90	M14	0,3	Acero latonado	1	D-39780	0088381399906	5,80
100	M14	0,3	Acero latonado	1	D-39805	0088381399920	7,60

**Copa ondulada de alambre trenzado** ★★

- Para superficies planas o rugosas. Alambre de acero más grueso que el tipo ondulado para trabajos más exigentes.



Ø (mm)	Inserción (mm)	Espesor (mm)	Tipo	Unds.	Código	EAN	P.V.P. (€)
60	M14	0,5	Acero	1	D-24119	0088381313711	5,60
75	M14	0,5	Acero	1	D-24131	0088381313735	6,20

**Copa recta ondulada de alambre trenzado** ★★

- Para superficies planas o rugosas. Alambre de acero más grueso que el tipo ondulado para trabajos más exigentes.



Ø (mm)	Inserción (mm)	Espesor (mm)	Tipo	Unds.	Código	EAN	P.V.P. (€)
60	M14	0,5	Acero	1	D-24153	0088381313759	7,00
100	M14	0,5	Acero	1	D-29290	0088381345842	10,20

**Cepillo oblicuo de alambre rizado** ★★

- Muy útil para limpiar esquinas o lugares estrechos donde los usuarios no pueden llegar con facilidad. Alambres oblicuos para que la superficie terminada quede mucho más suave.



Ø (mm)	Inserción (mm)	Espesor (mm)	Tipo	Unds.	Código	EAN	P.V.P. (€)
100	M14	0,3	Acero	1	D-39827	0088381399944	4,90
115	M14	0,3	Acero	1	D-39849	0088381399968	5,80

**Cepillos oblicuo de alambre trenzado** ★★

- Muy útil para limpiar esquinas o lugares estrechos donde los usuarios no pueden llegar con facilidad. Alambres oblicuos para que la superficie terminada quede mucho más suave.



Ø (mm)	Inserción (mm)	Espesor (mm)	Tipo	Unds.	Código	EAN	P.V.P. (€)
100	M14	0,5	Acero	1	D-39861	0088381399982	5,60
115	M14	0,5	Acero	1	D-39883	0088381400008	5,80
115	M14	0,5	Acero	1	D-29561	0088381346726	6,40
125	M14	0,5	Acero	1	D-29577	0088381346733	8,50
150	M14	0,5	Acero	1	D-45761	0088381410328	11,10
175	M14	0,5	Acero	1	D-45777	0088381410335	14,00



**Protectores de disco para amoladoras.**  
**Trabaja *sin polvo*. Cuida tu *salud*.**



Discos de diamante

# quasar



Discos de alta calidad para todo tipo de aplicaciones profesionales con la tecnología 3DDG de posicionamiento del diamante.

Tecnología STEALTH que utiliza 2 discos que hacen de molde sobre un núcleo de acero templado para reducir tanto las vibraciones como el ruido. Cortes más limpios y más rápidos.

**STEALTH  
TECHNOLOGY**

**30% MÁS DURACIÓN**

**50% MÁS RÁPIDO**



La altura de los segmentos se incrementa hasta los 12mm.



Dientes en forma de M que habilitan un buen inicio del corte.

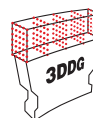

La tecnología 3D DiamondGrid es un avanzado método de fabricación del segmento que ordena los granos de diamante de forma paralela y uniforme por todo el segmento.

Soldadura láser que soporta grandes temperaturas.



Discos de diamante Quasar



- Quasar con cuerpo compacto, más silencioso, soldadura láser, banda segmentada, baja vibración, larga duración y tecnología STEALTH.

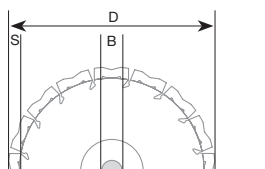

D (mm)	B (mm)	Reducción (mm)	S (mm)	Especificaciones	Uds.	Código	EAN	P.V.P. (€)
230	22,23	-	12	3DDG Stealth.	1	B-12712	0088381355452	148,00
300	20	-	12		1	B-13459	0088381359160	214,00
350	25,4	20	12		1	B-13465	0088381359177	276,00
400	25,4	20	12		1	B-13471	0088381359184	330,00



**Discos de diamante**



**30% MÁS DURACIÓN**

**50% MÁS RÁPIDO**

Aberturas de refrigeración para mantener el disco bien refrigerado durante el corte.

La altura de los segmentos se incrementa hasta los 10mm.

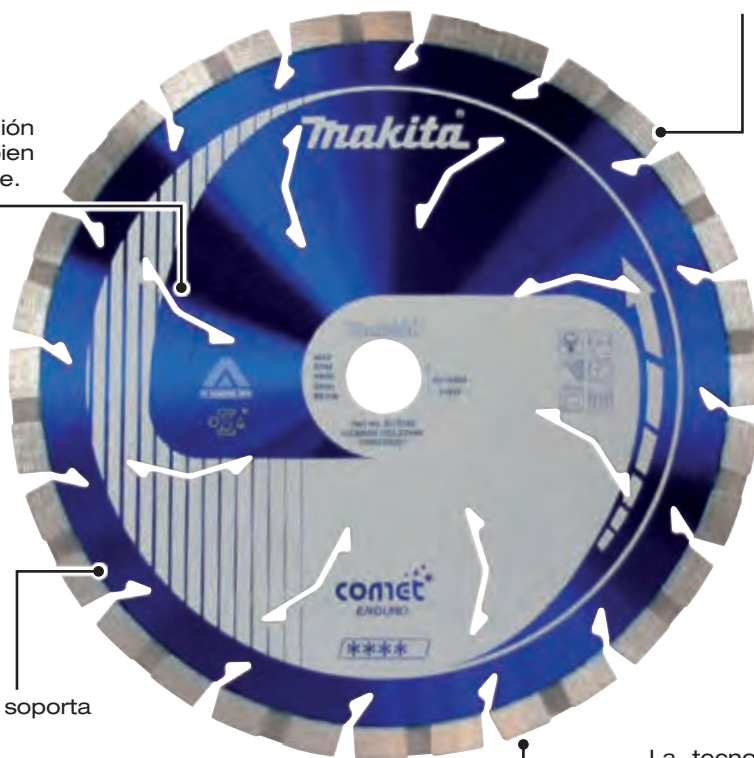

Dientes con rebaje en el centro que facilita la refrigeración.



Soldadura láser que soporta grandes temperaturas.

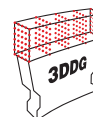

La tecnología 3D DiamondGrid es un avanzado método de fabricación del segmento que ordena los granos de diamante de forma paralela y uniforme por todo el segmento.



**Discos de diamante COMET**



- Cuerpo compacto, más silencioso.
- Con soldadura láser.
- Baja vibración.



Hormigón armado



Hormigón



Mármol Terrazo



Ladrillo medio/duro



Teja cerámica



Pizarra blanda

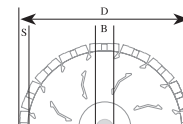
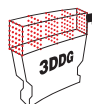

D (mm)	B (mm)	Reducción (mm)	S (mm)	Especificaciones	Uds.	Código	EAN	P.V.P. (€)
115	22,23	-	10	Aberturas de refrigeración	1	B-12762	0088381355506	48,00
125	22,23	20	10		1	B-12778	0088381355513	49,00
230	22,23	-	10	3DDG Aberturas de refrigeración Centro reforzado	1	B-12784	0088381355520	111,00
300	20	-	10		1	B-13546	0088381359252	166,00
350	25,4	20	10		1	B-13552	0088381359269	197,00
400	25,4	20	10		1	B-13568	0088381359276	238,00



### Discos de diamante COMET banda turbo



- Disco con banda turbo con el que obtenemos un buen acabado de la pieza de trabajo.
- Aberturas de refrigeración que evita dilataciones en el disco.
- Con soldadura láser para soportar altas temperaturas.

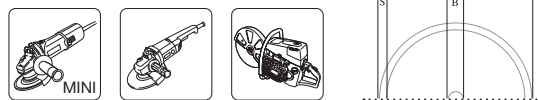

D (mm)	B (mm)	Reducción (mm)	S (mm)	Especificaciones	Uds.	Código	EAN	P.V.P. (€)
115	22,23	-	7	Banda turbo Núcleo estándar	1	B-12980	0088381358170	44,00
125	22,23	20	7		1	B-12996	0088381358187	49,00
150	22,23	20	7		1	B-13007	0088381358194	60,00
230	22,23	-	8		1	B-13035	0088381358224	97,00
300	25,4	-	8,5		1	B-13041	0088381358231	180,00
350	25,4	-	8,5		1	B-13057	0088381358248	235,00

### Discos de diamante COMET banda continua



- Perfecto acabado en los materiales más duros.
- Se recomienda trabajar con agua para su buena refrigeración.
- Soldadura láser para soportar altas temperaturas.

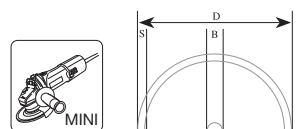

D (mm)	B (mm)	Reducción (mm)	S (mm)	Especificaciones	Uds.	Código	EAN	P.V.P. (€)
80	15	-	5	Banda continua Núcleo estándar	1	B-13063	0088381358255	76,00
115	22,23	-	5		1	B-13085	0088381358279	29,00
125	22,23	-	5		1	B-13091	0088381358286	31,00

### Discos de diamante COMET banda continua electrodepositada



- Disco de banda continua con el diamante electrodepositado especial para materiales muy compactos y que necesiten un corte muy limpio para evitar roturas.

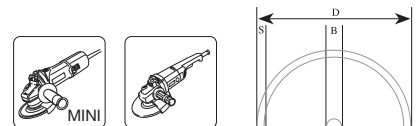

D (mm)	B (mm)	Reducción (mm)	S (mm)	Especificaciones	Uds.	Código	EAN	P.V.P. (€)
115	22,23	-	-	Electrodepositado Núcleo estándar	1	B-13172	0088381358378	58,00
125	22,23	20	-		1	B-13188	0088381358385	59,00
150	22,23	20	-		1	B-13194	0088381358392	79,00
230	22,23	-	-		1	B-13219	0088381358415	154,00
250	22,23	-	-		1	B-13225	0088381358422	281,00

**Discos de diamante COMET especial juntas**



- Diseño perfecto para en mortero, así como en materiales muy abrasivos.
- Para uso en mortero y ladrillo blando.
- Aberturas de refrigeración de gran tamaño.

• **Espesor 6,5mm**

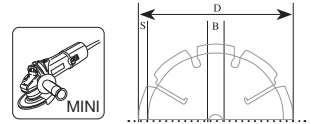

D (mm)	B (mm)	Reducción (mm)	S (mm)	Especificaciones	Uds.	Código	EAN	P.V.P. (€)
125	22,23	-	6,5	-	1	B-13253	0088381358453	103,00

**Discos de diamante COMET especial asfalto**



- Disco especial para trabajar en asfalto.
- Disco con pastilla de diamante de gran dureza ya que el asfalto es muy abrasivo.
- Banda segmentada para su refrigeración, pero se recomienda utilizar con cortadores de gasolina que tengan refrigeración con agua para una buena duración del disco.

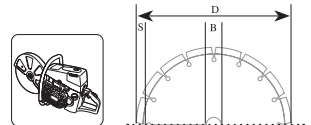

D (mm)	B (mm)	Reducción (mm)	S (mm)	Especificaciones	Uds.	Código	EAN	P.V.P. (€)
300	20	-	10	Asfalto Núcleo estándar	1	B-13269	0088381358460	185,00
350	25,4	20	10		1	B-13275	0088381358477	216,00

**Discos de diamante NEBULA**

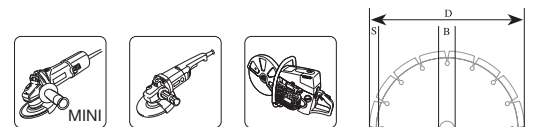

D (mm)	B (mm)	Reducción (mm)	S (mm)	Especificaciones	Uds.	Código	EAN	P.V.P. (€)
115	22,23	-	10	Soldadura láser	1	B-53986	0088381476485	25,00
125	22,23	-	10		1	B-53992	0088381476492	27,00
230	22,23	-	10		1	B-54025	0088381476522	35,00
300	20	-	10		1	B-54031	0088381476539	62,00
350	25,4	20	10		1	B-54053	0088381476553	79,00
400	25,4	20	10		1	B-54069	0088381476560	102,00



- Discos de uso general para el corte de todo tipo de materiales de obra.
- Apropriado para los materiales de mampostería.

**Discos de diamante DIAMAK banda segmentada**

- Gama económica de discos para trabajos generales de obra. Puede ser utilizado tanto en cortes secos como en húmedos. Disponible en banda segmentada, turbo y banda continua.
- Todo tipo de mampostería, bloque, ladrillo, pizarra y piedra caliza.

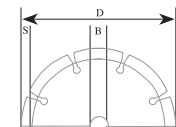

D (mm)	B (mm)	Reducción (mm)	S (mm)	Especificaciones	Uds.	Código	EAN	P.V.P. (€)
115	22,23	-	7	Banda segmentada Núcleo estándar	1	D-61123	0088381475778	8,70
125	22,23	-	7		1	D-52766	0088381445177	8,70
150	22,23	-	7		1	B-06432	0088381276122	22,00
230	22,23	-	7		1	D-61145	0088381475792	18,70
300	25,40	-	7,5		1	D-56982	0088381458085	67,00
350	25,40	-	7,5		1	D-56998	0088381458092	83,00
400	25,40	-	7,5		1	D-57009	0088381458108	97,00



- Nuevo expositor de cartón. Incluye 10 Uds.



125	22,23	-	7	Banda segmentada Núcleo estándar	10	D-41595-10	0088381435376	88,00
-----	-------	---	---	-------------------------------------	----	------------	---------------	-------

**Discos de diamante DIAMAK banda turbo**

- Para materiales duros, granito, materiales arcillosos, pizarra, piedra caliza y hormigón duro.
- Banda segmentada.
- Núcleo estándar.

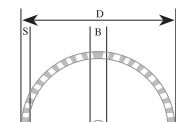

D (mm)	B (mm)	Reducción (mm)	S (mm)	Especificaciones	Uds.	Código	EAN	P.V.P. (€)
115	22,23	-	7	Banda segmentada Núcleo estándar	1	D-61151	0088381475808	8,70
125	22,23	20	7		1	D-61167	0088381475815	10,00
230	22,23	-	7		1	D-61173	0088381475822	22,00

**Discos de diamante DIAMAK banda continua**

- Para materiales duros, granito, materiales arcillosos, pizarra, piedra caliza y hormigón duro.

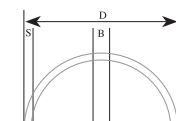

D (mm)	B (mm)	Reducción (mm)	S (mm)	Especificaciones	Uds.	Código	EAN	P.V.P. (€)
110	22,23	-	7	Banda continua Núcleo estándar	1	D-61189	0088381475839	7,50



**Disco de diamante especial para herramientas a batería**



- Nuevo disco de diamante de 230 mm ideal para cortadores a batería.
- Con este disco conseguimos aumentar la velocidad de corte y la vida útil del mismo.
- Para conseguir ranuras más estrechas, diseñamos el segmento en forma de abanico, obteniendo un mejor rendimiento de trabajo. Los diamantes se distribuyen regularmente en la estructura del segmento, así se logra un rendimiento de trabajo estable y reduce el consumo de batería.



**N**

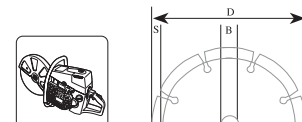

D (mm)	B (mm)	Reducción (mm)	S (mm)	Especificaciones	Uds.	Código	EAN	P.V.P. (€)
230	22,23	-	7	especial para DCE090	1	E-02967	0088381475792	149,00
355	25,4	-	8	CE001	1	E-23226	0197050352897	165,00



**Discos de diamante X-LOCK**



- Disco de diamante segmentado X-LOCK 115x22,23 mm.
- Los discos de diamante compatibles con las amoladoras X-LOCK permiten una instalación de disco fácil y segura.

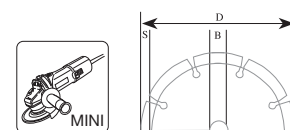

D (mm)	B (mm)	Reducción (mm)	S (mm)	Especificaciones	Uds.	Código	EAN	P.V.P. (€)
115	22,23	-	7	Compatible con amoladoras X-LOCK	1	E-02060	0088381556217	40,00
125	22,23	-	7		1	E-02076	0088381556224	43,00

**Disco de diamante electrodepositado X-LOCK**



- Disco de diamante segmentado X-LOCK 125x22,23 mm.
- Discos de diamante compatible con las amoladoras X-LOCK permiten una instalación de disco fácil y segura.
- Multimaterial.



**N**

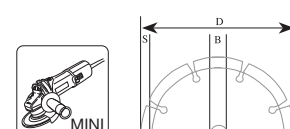

D (mm)	B (mm)	Reducción (mm)	S (mm)	Especificaciones	Uds.	Código	EAN	P.V.P. (€)
125	22,23	-	7	Compatible con amoladoras X-LOCK	1	E-19738	0088381787680	70,00



**Discos de diamante especial vidrio y porcelánico**



- Segmentos continuos para un corte limpio sin rotura de las aristas de corte de azulejos, cerámica, mármol, vidrio, etc.



D (mm)	B (mm)	Modelo	Uds.	Código	EAN	P.V.P. (€)
85	15	CC301D	1	B-21098	0088381399777	37,00

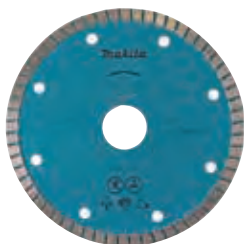

- Segmento continuo e inclinado de anchura extra fina de 1,2 mm para el corte rápido y limpio de azulejos, mármol y vidrio.



D (mm)	B (mm)	Modelo	Uds.	Código	EAN	P.V.P. (€)
110	20	4101RH	1	B-22028	0088381401760	101,00



- Perfecto acabado en los materiales más duros. Se recomienda trabajar con agua para su buena refrigeración. Soldadura láser para soportar altas temperaturas. Indicado para hormigón y porcelánico (no válido para vidrio).



D (mm)	B (mm)	Modelo	Uds.	Código	EAN	P.V.P. (€)
125	20	4101RH	1	B-21951	0088381401692	40,00



- Especial porcelánico.
- Disco extrafino, ideal para máquinas a batería.
- 1,4 mm.



D (mm)	B (mm)	Modelo	Uds.	Código	EAN	P.V.P. (€)
115	22,23	Amoladoras 115 mm	1	B-46327	0088381452403	39,00



- Especial porcelánico.
- Disco extrafino, ideal para máquinas a batería.
- 1,4 mm.



D (mm)	B (mm)	Modelo	Uds.	Código	EAN	P.V.P. (€)
125	22,23	Amoladoras 125 mm	1	B-46333	0088381452410	42,00

**Discos para cortador DMC300**

**Disco de diamante**



Ø ext (mm)	Ø int (mm)	Uds.	Código	EAN	P.V.P. (€)
76	10	1	D-77263	0088381789608	6,25

**Disco de carburo de Tungsteno**



Ø ext (mm)	Ø int (mm)	Uds.	Código	EAN	P.V.P. (€)
76	10	1	D-74837	0088381590877	5,25

**Discos de diamante especial rescate multimaterial**



- Corta todo tipo de materiales: Metal, plástico, madera, cristal, ladrillo, fibrocemento, hormigón...
- Perfecto para operaciones de rescate.
- Muy utilizado en parques de bomberos.

D (mm)	B (mm)	Modelo	Uds.	Código	EAN	P.V.P. (€)
125	22,23	Amoladoras 125 mm	1	B-55310	0088381482035	56,00
230	22,23	Amoladoras 230 mm	1	B-55326	0088381482042	104,00
305	25,4	Amoladoras 305 mm	1	B-55332	0088381482059	187,00
355	25,4	Amoladoras 350 mm	1	B-55348	0088381482066	231,00

B-55326



**Discos de diamante para pulir hormigón**



B-12289

- Disco para limpiar y pulir superficies de hormigón y piedra natural con un acabado fino.



B-12295

- Disco para limpiar rápidamente capas gruesas de hormigón.



D-41464

- Gama económica.
- Disco para limpiar y pulir superficies de hormigón y piedra natural con un acabado fino.

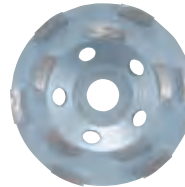

D-41458

- Gama económica.
- Disco para limpiar rápidamente capas gruesas de hormigón.

D (mm)	B (mm)	Modelo	Uds.	Código	EAN	P.V.P. (€)
125	22,23	PC5010C	1	B-12289	0088381354042	225,00
125	22,23	PC5010C	1	B-12295	0088381354059	110,00
125	22,23	PC5010C	1	D-41464	0088381404280	66,00
125	22,23	PC5010C	1	D-41458	0088381404273	58,00



**Corte en húmedo - 1-1/4"**



Ø (mm)	Longitud (mm)	Uds.	Código	EAN	P.V.P. (€)
32	450	1	E-19869	0088381788458	134,00
42	450	1	E-19875	0088381788465	149,00
52	450	1	E-19881	0088381788472	170,00
62	450	1	E-19897	0088381788489	193,00
68	450	1	E-19906	0088381788496	218,00
72	450	1	E-19912	0088381788502	228,00
82	450	1	E-19928	0088381788519	250,00
92	450	1	E-19934	0088381788526	290,00
102	450	1	E-19940	0088381788533	297,00
107	450	1	E-19956	0088381788540	320,00
112	450	1	E-19962	0088381788557	332,00
117	450	1	E-19978	0088381788564	338,00
122	450	1	E-19984	0088381788571	355,00
127	450	1	E-19990	0088381788588	410,00
132	450	1	E-20002	0088381788595	419,00
142	450	1	E-20018	0088381788601	436,00
152	450	1	E-20024	0088381788618	468,00
162	450	1	E-20030	0088381788625	485,00
172	450	1	E-20046	0088381788632	565,00
182	450	1	E-20052	0088381788649	588,00
202	450	1	E-20068	0088381788656	662,00
212	450	1	E-20074	0088381788663	820,00

**Brocas diamante para taladro**



- Húmedo.
- Porcelánico y cerámica.

Ø (mm)	Inserción (mm)	Uds.	Código	EAN	P.V.P. (€)
6	8	1	D-77372	0088381718288	8,50
8	8	1	D-77388	0088381718295	9,00
10	8	1	D-77394	0088381718301	9,50
12	8	1	D-77403	0088381718318	10,00



**Brocas de corona para amoladora (especial mármol)**



- Perforación más rápida.
- Sencilla obtención del punto de taladrado basculando la máquina.
- Válidas para trabajar en mármol y granito. Sólo utilizar en seco.

Ø (mm)	Medida	Uds.	Código	EAN	P.V.P. (€)
25	M14	1	D-35025	-	23,00
30	M14	1	D-35019	-	27,00
35	M14	1	D-35003	0088381360272	28,00

**Brocas especiales para amoladora  
(especial porcelánico)**



D-44507



D-61070

Ø (mm)	Medida	Uds.	Código	EAN	P.V.P. (€)
5	M14	1	D-79902	0197050358080	17,00
6	M14	1	D-79918	0197050358097	18,60
8	M14	1	D-79924	0197050358103	19,20
10	M14	1	D-79930	0197050358110	20,00
12	M14	1	D-79946	0197050358127	28,00
14	M14	1	D-44432	0088381406758	39,00
20	M14	1	D-44454	0088381406772	30,00
25	M14	1	D-44476	0088381406796	37,00
32	M14	1	D-44507	0088381406826	47,00
35	M14	1	D-44513	0088381406833	48,50
38	M14	1	D-44529	0088381406840	59,00
60	M14	1	D-44585	0088381406901	82,00
65	M14	1	D-44591	0088381406918	89,00
68	M14	1	D-44616	0088381406932	94,00
75	M14	1	D-44638	0088381406956	104,00

**Accesorios para PW5000CH**



**Discos pulidores de diamante**



- Discos pulidores de 100 mm para el perfecto pulido de la piedra.
- Fijación a la base por velcro.

Grano	Ø (mm)	Tipo	Color	Uds.	Código	EAN	P.V.P. (€)
50	100	Velcro	Azul	1	D-15584	0088381186759	15,90
200			Naranja	1	D-15609	0088381186773	15,90
800			Verde oscuro	1	D-15621	0088381186797	15,90
3.000			Marrón	1	D-15643	0088381186810	15,90
PIEL			Verde	1	D-15659	0088381186827	26,00

**Plato de velcro**



Ø (mm)	Tipo	Uds.	Código	EAN	P.V.P. (€)
100	Velcro	1	743080-0	0088381201223	27,00







**Discos abrasivos de desbarbe** ★★★★★



Material	Ø ext. (mm)	Ø int. (mm)	Espesor (mm)	Uds.	Código	EAN	P.V.P. (€)
Metal	115	22,23	6,4	1	P-52978	0088381983488	1,65
Metal	125	22,23	6,4	1	P-52984	0088381983495	1,95
Metal	150	22,23	6,4	1	P-52990	0088381983501	2,80
Metal	180	22,23	7	1	P-52227	0088381982733	3,30
Metal	230	22,23	7	1	P-52819	0088381983327	4,70

**Discos abrasivos grano cerámico** ★★★★★

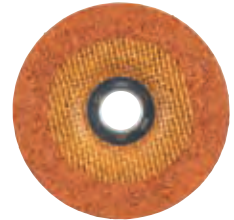

Material	Ø ext. (mm)	Ø int. (mm)	Espesor (mm)	Uds.	Código	EAN	P.V.P. (€)
A24P	125	22,23	6	1	B-66927	0088381540070	16,00

**Discos abrasivos de desbarbe** ★★



Material	Ø ext. (mm)	Ø int. (mm)	Espesor (mm)	Uds.	Código	EAN	P.V.P. (€)
Metal	115	22,23	6	20	D-18459-20	0088381583992	27,00
Metal	125	22,23	6	20	D-18465-20	0088381584005	32,00

**Discos abrasivos de corte**

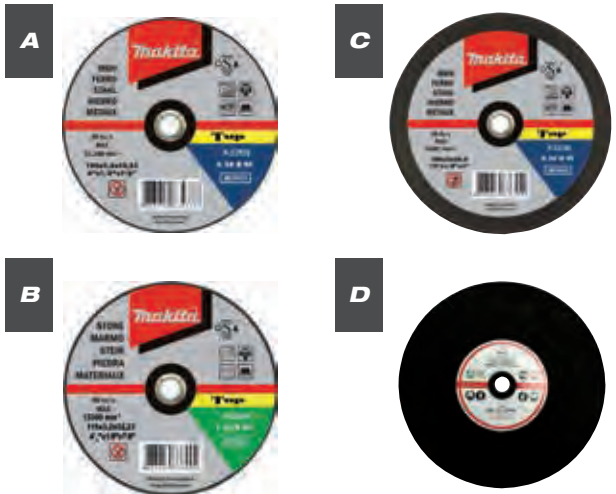

**Discos abrasivos de desbarbe** ★



Material	Ø ext. (mm)	Ø int. (mm)	Espesor (mm)	Uds.	Código	EAN	P.V.P. (€)
Metal	115	22,23	6	1	D-74485	0088381587709	1,05
Metal	125	22,23	6	1	D-74491	0088381587716	1,35
Metal	230	22,23	6	1	D-74522	0088381587747	3,20

**Discos abrasivos de desbarbe para metal especial industria pesada** ★★★★★



Material	Ø ext. (mm)	Ø int. (mm)	Espesor (mm)	Uds.	Código	EAN	P.V.P. (€)
Inox	115	22,23	7,2	1	B-56378	0088381490061	3,90
Inox	125	22,23	7,2	1	B-56390	0088381490085	4,40

Material	Ø ext. (mm)	Ø int. (mm)	Espesor (mm)	Uds.	Código	EAN	P.V.P. (€)
Metal <b>A</b>	115	22,23	3,2	1	P-52174	0088381982689	1,20
	125	22,23	3,2	1	P-52180	0088381982696	1,40
	150	22,23	3,2	1	P-52928	0088381983433	1,95
	180	22,23	3,2	1	P-52934	0088381983440	1,95
	230	22,23	3,2	1	P-52196	0088381982702	2,55
Piedra <b>B</b>	115	22,23	3,2	1	P-52205	0088381982719	1,40
	125	22,23	3,2	1	P-52940	0088381983457	1,65
	180	22,23	3,2	1	P-52962	0088381983471	2,20
	230	22,23	3,2	1	P-52211	0088381982726	3,05
Metal <b>C</b>	300	25,4	3	1	P-53148	0088381983655	4,10
	350	25,4	3	1	P-53154	0088381983662	5,75
	400	20	4	1	724409-9	-	46,00
Piedra <b>D</b>	300	20	3,2	1	721710-3	-	16,50
	350	25,4	4	1	721715A3	-	25,00
	400	20	4,7	1	724406-5	-	46,00



**Discos abrasivos de desbarbe**

**XLOCK**



★★★

Material	Ø ext. (mm)	Ø int. (mm)	Espesor (mm)	Uds.	Código	EAN	P.V.P. (€)
Metal	115	22,23	6	1	E-00365	0088381555395	1,85
Metal	125	22,23	6	1	E-00393	0088381555425	2,20
Inox	115	22,23	6	1	E-00371	0088381555401	2,40
Inox	125	22,23	6	1	E-00402	0088381555432	3,00

**Discos abrasivos extrafinos de corte**

**XLOCK**



★★★

Material	Ø ext. (mm)	Ø int. (mm)	Espesor (mm)	Uds.	Código	EAN	P.V.P. (€)
Metal	115	22,23	1,2	1	E-00387	0088381555418	2,00
Metal	125	22,23	1,2	1	E-00418	0088381555449	2,20

**Discos abrasivos extrafinos de corte**



★★★★

Material	Ø ext. (mm)	Ø int. (mm)	Espesor (mm)	Uds.	Código	EAN	P.V.P. (€)
Metal	115	22,23	1	1	P-53001	0088381983518	1,40
	115	22,23	1,6	1	P-53017	0088381983525	1,40
	125	22,23	1	1	P-53023	0088381983532	1,45
	125	22,23	1,6	1	P-53039	0088381983549	1,45
	230	22,23	2	1	P-52233	0088381982740	3,30
Inox	115	22,23	1	1	P-52249	0088381982757	1,40
	115	22,23	1,6	1	P-52255	0088381982764	1,40
	125	22,23	1	1	P-53045	0088381983556	1,40
	125	22,23	1,6	1	P-53051	0088381983563	1,45
Piedra	230	22,23	2	1	P-53067	0088381983570	3,30
	115	22,23	1	1	P-53073	0088381983587	1,40
	115	22,23	1,6	1	P-53089	0088381983594	1,95
Aluminio	125	22,23	1	1	P-53095	0088381983600	1,45
	115	22,23	1,6	1	P-53126	0088381983631	1,40

**Paquetes de discos de corte fino**



★★

Material	Ø ext. (mm)	Ø int. (mm)	Espesor (mm)	Uds.	Código	EAN	P.V.P. (€)
Inox	115	22,23	1	10	D-65953-10	0088381561815	7,40
Inox	125	22,23	1	10	D-65969-10	0088381561822	8,50

**Discos abrasivos extrafinos de corte**



Material	Ø ext. (mm)	Ø int. (mm)	Espesor (mm)	Uds.	Código	EAN	P.V.P. (€)
INOX.	115	22,23	1	1	D-75524	0088381595285	1,05
	125	22,23	1	1	D-75530	0088381595292	1,05
	230	22,23	2	1	D-75568	0088381595322	2,10

**Disco abrasivo para DCE090**

★★★

- Para corte rápido.
- Produce menos polvo y rebaba de los materiales.



Material	Ø ext. (mm)	Ø int. (mm)	Espesor (mm)	Uds.	Código	EAN	P.V.P. (€)
Inox	230	22,23	2	25	E-03006-25	0088381567442	61,00

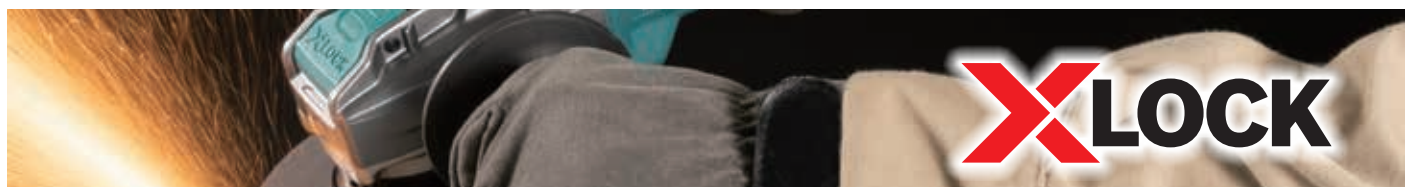

**Discos de láminas - Óxido de aluminio cerámico**



- Ideal para inoxidable, titanio, níquel y otros metales de gran densidad.
- La gama alta de los discos de láminas.



**Tipo curvo**



**Cuerpo de fibra de vidrio**

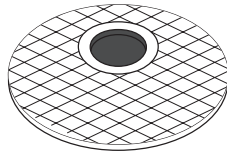

**Materiales**

- Metal
- Acero inoxidable
- Metales no férricos

Ø ext. (mm)	Ø int. (mm)	Grano	R.p.m	Uds.	Código	EAN	P.V.P. (€)
180	22,23	40	8.600	1	D-28379	0088381344975	14,30
		60	8.600		D-28385	0088381344982	14,30
		80	8.600		D-28391	0088381344999	14,30
		120	8.600		D-28400	0088381345002	14,30

**Discos de láminas - Carburo de silicio**



- Discos con abrasivo de carburo de silicio muy efectivo en materiales como el ladrillo, piedra y hormigón.
- No es necesario trabajarlo con agua.



**Tipo plano**



**Cuerpo de fibra de vidrio**

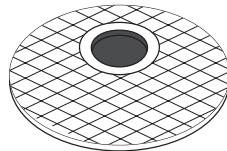

**Materiales**

- Ladrillo, piedra y hormigón

Ø ext. (mm)	Ø int. (mm)	Grano	R.p.m	Uds.	Código	EAN	P.V.P. (€)
115	22,23	40	13.290	1	D-28036	0088381344630	4,00
		60	13.290		D-28042	0088381344647	4,00
		80	13.290		D-28058	0088381344654	4,00
		120	13.290		D-28064	0088381344661	4,00
125	22,23	40	13.290	1	D-28086	0088381344685	4,50
		60	13.290		D-28092	0088381344692	4,50
		80	13.290		D-28101	0088381344708	4,50
		120	13.290		D-28117	0088381344715	4,50
180	22,23	40	8.600	1	D-28139	0088381344739	7,70
		60	8.600		D-28145	0088381344746	7,70
		80	8.600		D-28151	0088381344753	7,70
		120	8.600		D-28167	0088381344760	8,25

- Discos de nylon para los trabajos más exigentes. Indicados para lijados donde debemos ejercer gran presión sobre el material, consiguiendo así un poder de lijado mayor. Mayor rendimiento y mayor calidad.



**Tipo plano**



**Cuerpo de nylon**

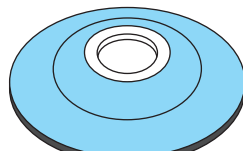

**Materiales**

Ø ext. (mm)	Ø int. (mm)	Grano	R.p.m	Uds.	Código	EAN	P.V.P. (€)
115	22,23	40	13.290	1	D-28173	0088381344777	5,50
		60	13.290		D-28189	0088381344784	5,50
		80	13.290		D-28195	0088381344791	5,50
		120	13.290		D-28204	0088381344807	5,50
180	22,23	40	8.600	1	D-28210	0088381344814	11,00
		60	8.600		D-28226	0088381344821	11,00
		80	8.600		D-28232	0088381344838	11,00
		120	8.600		D-28248	0088381344845	11,00

**Discos de láminas X-LOCK - Zirconio**



- Material abrasivo de Zirconio. Para trabajar metales no ferrosos y acero Inox.
- Sistema X-Lock, facilita la colocación y extracción del disco.

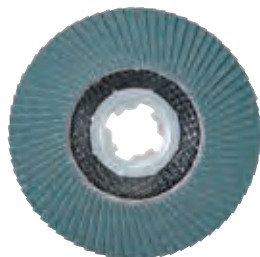

Cuerpo de fibra de vidrio

Tipo curvo

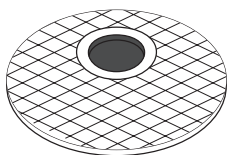

Materiales



N  
N  
N  
N  
N

Ø ext. (mm)	Ø int. (mm)	Grano	R.p.m	Uds.	Código	EAN	P.V.P. (€)
125	22,23	36		1	D-75998	88381599177	6,50
		40			D-76009	88381599184	6,50
		60			D-76015	88381599191	6,00
		80			D-76021	88381599207	6,00
		120			D-76037	88381599214	6,00



Metal



Metales no ferrosos



Acero inoxidable

**Discos de láminas - Zirconio**



- Discos con abrasivo de Zirconio perfecto para los trabajos en metales y trabajos en acero inoxidable.
- “El disco más popular del mercado”.



Tipo curvo



Cuerpo de fibra de vidrio

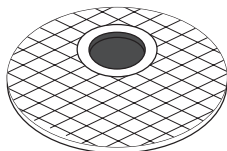

Materiales



Metal



Acero inoxidable



Metales no ferrosos

Tipo curvo

Ø ext. (mm)	Ø int. (mm)	Grano	R.p.m	Uds.	Código	EAN	P.V.P. (€)
115	22,23	40	13.290	1	D-53724	0088381445320	3,10
		60	13.290		D-53730	0088381445337	3,10
		80	13.290		D-53746	0088381445344	3,10
		120	13.290		D-53752	0088381445351	3,10
180		40	8.600	1	D-53827	0088381445429	8,00
		60	8.600		D-53833	0088381445436	8,00
		80	8.600		D-53849	0088381445443	8,00
		120	8.600		D-53855	0088381445450	8,00

Tipo curvo

Ø ext. (mm)	Ø int. (mm)	Grano	R.p.m	Uds.	Código	EAN	P.V.P. (€)
115		40	13.290	1	D-63747	0088381525350	2,00
		60	13.290		D-63753	0088381525367	2,00
		80	13.290		D-63769	0088381525374	2,00
		120	13.290		D-63775	0088381525381	2,00
125	22,23	40	13.290	1	D-63781	0088381525398	2,30
		60	13.290		D-63797	0088381525404	2,30
		80	13.290		D-63806	0088381525411	2,25
		120	13.290		D-63812	0088381525428	2,25
180		40	8.600	1	D-63828	0088381525435	4,50
		60	8.600		D-63834	0088381525442	4,50
		80	8.600		D-63840	0088381525459	4,50
		120	8.600		D-63856	0088381525466	4,50





Tipo plano

Ø ext. (mm)	Ø int. (mm)	Grano	R.p.m	Uds.	Código	EAN	P.V.P. (€)
115		40	13.290	1	D-74186	0088381587228	1,85
		60	13.290		D-74192	0088381587235	1,85
		80	13.290		D-74201	0088381587242	1,85
		120	13.290		D-74217	0088381587259	1,85
125	22,23	40	13.290	1	D-74223	0088381587266	2,15
		60	13.290		D-74239	0088381587273	2,15
		80	13.290		D-74245	0088381587280	2,15
		120	13.290		D-74251	0088381587297	2,15
180		40	8.600	1	D-74267	0088381587303	4,50
		60	8.600		D-74273	0088381587310	4,50
		80	8.600		D-74289	0088381587327	4,50
		120	8.600		D-74295	0088381587334	4,50





**Empuñaduras**

Modelo	Descripción	Uds.		Código	EAN	P.V.P. (€)
Para amoladoras de: 115 mm 125 mm 150 mm	Rígida	1		153489-2	0088381193054	1,20
	Antivibración	1		162258-0	0088381343381	13,70
Para amoladoras: 9015B 9016B Lijadora 9218SB	Rígida	1		152492-0	0088381131599	3,05
Para amoladoras: 180 mm 230 mm	Antivibración	1		162264-5	0088381345828	16,10
	De corte	1		194684-5	0088381349895	14,80



**Colectores de polvo**

El polvo puede causar graves enfermedades respiratorias. Para tratar de evitarlas Makita recomienda utilizar colector de polvo con una tasa de aspiración hasta del 90% de las partículas. Carcasa en aluminio para una mayor duración. Posibilidad de bloquear el disco a la profundidad deseada. Visor con protector transparente.

**Colector de polvo amoladoras 230 mm**



Ø (mm)	Descripción	Uds.	Código	EAN	P.V.P. (€)
230	Aluminio. Posibilidad de bloquear el disco. Visor transparente.	1	198440-5	0088381487368	150,00

**Colector de polvo amoladoras 125 mm**



Ø (mm)	Descripción	Uds.	Código	EAN	P.V.P. (€)
125	Aluminio. Posibilidad de bloquear el disco. Visor transparente.	1	196845-3	0088381442527	81,00
125	Con enganche rápido sin herramientas*	1	191G06-2	0088381566001	87,00

\* Para amoladoras con enganche rápido de protector de disco.

Colectores de polvo aptos para amoladoras de 115 mm, 125 mm y 180 mm. Especial para su uso en lijados con discos de diamante en hormigón. Modelos de amoladoras compatibles: potencia 1.100W o superior. Alta capacidad de aspiración. Apta para rincones gracias a su sistema de dos piezas.

Modelos	Diámetro (mm)	Descripción	Uds.	Código	EAN	P.V.P. (€)
Amoladoras 115 / 125 mm X-LOCK.	115 / 125	Especial para su uso en lijados con discos.	1	191F81-2	0088381565479	52,00
Amoladoras 115 mm / 125 mm.	115 / 125		1	195239-9	0088381361804	52,00
Amoladoras 180 mm.	180		1	195385-8	0088381369381	71,00



**Lijadoras orbitales**

**Lijas para BO4565**

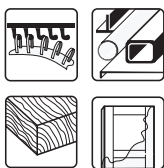

- Excelente rendimiento de lijado en aplicaciones profesionales.
- Aplicaciones: lijado de madera, hierro y madera pintada.
- Óxido de aluminio extra resistente y agarre por velcro. Orificios de aspiración 3+3.

Medida (mm)	Grano	Uds.	Código	EAN	P.V.P. (€)
114 x 102	40	10	P-33087	0088381961240	5,00
	60		P-33093	0088381961257	5,00
	80		P-33102	0088381961264	5,00
	100		P-33118	0088381961271	5,00
	120		P-33124	0088381961288	4,40
	150		P-33130	0088381961295	4,40
	180		P-33146	0088381961301	4,40
	240		P-33152	0088381961318	4,40
	320		P-33168	0088381961325	4,40

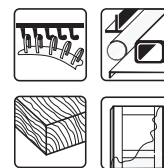

- Para el uso con la mayoría de lijadoras tipo delta con base triangular.
- Aplicaciones: lijado de madera, metal. Ideal para esquinas y lijado de acabado.
- Lija triangular con agarre por velcro y 6 orificios para aspiración.

Medida (mm)	Grano	Uds.	Código	EAN	P.V.P. (€)
93 x 93 x 93	40	10	P-33255	0088381961417	4,10
	60		P-33261	0088381961424	4,10
	80		P-33277	0088381961431	4,10
	100		P-33283	0088381961448	3,90
	120		P-33299	0088381961455	3,90
	150		P-33308	0088381961462	3,90
	180		P-33314	0088381961479	3,90
	240		P-33320	0088381961486	3,90
	320		P-33336	0088381961493	3,90



- Especial pintura. Excelente rendimiento en aplicaciones profesionales. 6 orificios de aspiración.<sup>1</sup>
- Aplicaciones: lijado de pintura, barniz, madera pintada.

Medida (mm)	Grano	Uds.	Código	EAN	P.V.P. (€)
114 x 102	40	10	P-35807	0088381964968	5,80
	60		P-35813	0088381964975	5,50
	80		P-35829	0088381964982	5,20
	100		P-35835	0088381964999	5,20
	120		P-35841	0088381965002	5,20
	150		P-35857	0088381966016	5,20
	180		P-35863	0088381966023	5,20
	240		P-35879	0088381966030	5,20
	320		P-35885	0088381966047	5,20



- Especial pintura. Para el uso con la mayoría de lijadoras tipo delta con base triangular. 6 orificios de aspiración.
- Excelente rendimiento en aplicaciones profesionales.
- Aplicaciones: lijado de pintura, barniz, madera pintada.

Medida (mm)	Grano	Uds.	Código	EAN	P.V.P. (€)
93 x 93 x 93	40	10	P-42684	0088381970556	4,40
	60		P-42690	0088381970563	4,10
	80		P-42709	0088381970570	4,10
	100		P-42715	0088381970587	4,10
	120		P-42721	0088381970594	4,10
	150		P-42737	0088381970600	4,10
	180		P-42743	0088381970617	4,10
	240		P-42759	0088381970624	4,10
	320		P-42765	0088381970631	4,10

**Lijadoras orbitales**

**Lijas para BO3700 / 9036 / BO3711 / DBO380 / DBO381**

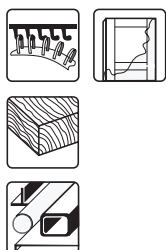

- Excelente rendimiento de lijado en aplicaciones profesionales.
- Aplicaciones: Lijado de madera, hierro y madera pintada. Perforaciones 4+4.

Medida (mm)	Grano	Uds.	Código	EAN	P.V.P. (€)
93 x 185	40	10	P-31871	0088381960038	5,50
	60		P-31887	0088381960045	5,00
	80		P-31893	0088381960052	5,00
	100		P-31902	0088381960069	5,00
	120		P-35891	0088381966054	5,00
	150		P-35900	0088381966061	5,00
	180		P-35916	0088381966078	5,00
	240		P-35922	0088381966085	5,00



- Excelente rendimiento de lijado en aplicaciones profesionales.
- Lija de grano abierto de corindón con doble recubrimiento de resina.
- Ideal para el lijado de maderas secas, pintadas o barnizadas.
- También válida para metal. Perfecta para ebanistería y carrocería.

Medida (mm)	Grano	Uds.	Código	EAN	P.V.P. (€)
93 x 228	40	10	P-36136	0088381966290	3,30
	60		P-32948	0088381961103	3,05
	80		P-36142	0088381966306	3,05
	100		P-32954	0088381961110	3,05
	120		P-36158	0088381966313	3,05
	150		P-32960	0088381961127	2,45



- Excelente rendimiento de lijado en aplicaciones profesionales.
- Lija de grano abierto de corindón con doble recubrimiento de resina.
- Ideal para el lijado de maderas secas, pintadas o barnizadas. También válida para metal.
- Perfecta para ebanistería y carrocería.
- Perforaciones 4+4.

Medida (mm)	Grano	Uds.	Código	EAN	P.V.P. (€)
93 x 228	40	10	P-31837	0088381959995	3,90
	60		P-31843	0088381960007	3,60
	80		P-31859	0088381960014	3,60
	100		P-31865	0088381960021	3,60
	120		P-36011	0088381966177	3,60
	150		P-36027	0088381966184	3,60
	180		P-36033	0088381966191	3,60
	240		P-36049	0088381966207	3,60



**Makita**



**Lijadoras orbitales**

**Lijas para BO4900V / 9046 / BO4901**

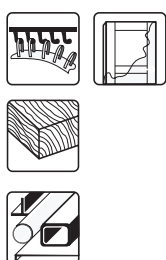

- Excelente rendimiento de lijado en aplicaciones profesionales.
- Lija de grano abierto de corindón con doble recubrimiento de resina.
- Ideal para el lijado de maderas secas, pintadas o barnizadas.
- También válida para metal.
- Perfecta para ebanistería y carrocería.
- Perforaciones 5+5.

Medida (mm)	Grano	Uds.	Código	EAN	P.V.P. (€)
115 x 229	40	10	P-33174	0088381961332	6,90
	60		P-33180	0088381961349	6,60
	80		P-33196	0088381961356	6,60
	100		P-33205	0088381961363	6,60
	120		P-33211	0088381961370	6,60
	180		P-33233	0088381961394	6,30
	240		P-33249	0088381961400	6,30

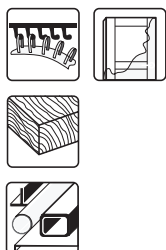
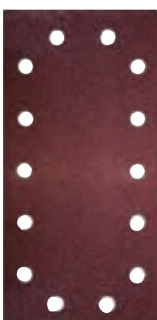

- Lija de alta resistencia. Excelente rendimiento de lijado en aplicaciones profesionales.
- Lija de grano abierto de corindón con doble recubrimiento de resina.
- Ideal para el lijado de maderas secas, pintadas o barnizadas. También válida para metal.
- Perfecta para ebanistería y carrocería.
- Perforaciones 5+5+2+2.

Medida (mm)	Grano	Uds.	Código	EAN	P.V.P. (€)
115 x 229	40	10	P-43022	0088381970891	7,70
	60		P-43038	0088381970907	7,20
	80		P-43044	0088381970914	6,90
	100		P-43050	0088381970921	6,60
	120		P-43066	0088381970938	6,60
	150		P-43072	0088381970945	6,00
	180		P-43088	0088381970952	6,60
	240		P-43094	0088381970969	6,60



- Excelente rendimiento de lijado en aplicaciones profesionales.
- Lija de grano abierto de corindón con doble recubrimiento de resina.
- Ideal para el lijado de maderas secas, pintadas o barnizadas.
- También válida para metal.
- Perfecta para ebanistería y carrocería.
- Perforaciones 5+5+2+2.

Medida (mm)	Grano	Uds.	Código	EAN	P.V.P. (€)
115 x 280	40	10	P-33009	0088381961165	4,70
	60		P-33015	0088381961172	4,40
	80		P-33021	0088381961189	4,40
	100		P-33037	0088381961196	4,40
	120		P-33043	0088381961202	4,40
	150		P-33059	0088381961219	4,40
	180		P-33065	0088381961226	4,40
	240		P-33071	0088381961233	4,10



- Excelente rendimiento de lijado en aplicaciones profesionales.
- Lija de grano abierto de corindón con doble recubrimiento de resina.
- Ideal para el lijado de maderas secas, pintadas o barnizadas.
- También válida para metal.
- Perfecta para ebanistería y carrocería.

Medida (mm)	Grano	Uds.	Código	EAN	P.V.P. (€)
115 x 280	40	10	P-36267	0088381966429	4,40
	60		P-32976	0088381961134	4,10
	80		P-36273	0088381966436	4,10
	100		P-32982	0088381961141	4,10
	120		P-36289	0088381966443	4,10
	150		P-32998	0088381961158	3,30

**Lijadoras orbitales**

**Rollos de lija**



- Para uso general. Válido para madera, metal, pintura y barniz.
- Rollo de 5 m.
- Ideal para lijadoras orbitales.
- Válido como lija de mano.

Ancho (mm)	Grano	Longitud (m)	Uds.	Código	EAN	P.V.P. (€)
120	40	5	1	P-38102	0088381973816	8,60
	60			P-38118	0088381973823	6,60
	80			P-38124	0088381973830	5,80
	100			P-38130	0088381973847	5,50
	120			P-38146	0088381973854	5,50
	180			P-38152	0088381973861	5,50
	240			P-38168	0088381973878	5,50
	320			P-38174	0088381973885	5,50
	400			P-38180	0088381973892	4,40



- Para uso general. Válido para madera, metal, pintura y barniz.
- Rollo de 50 m.
- Ideal para lijadoras orbitales.
- Válido como lija de mano.

Ancho (mm)	Grano	Longitud (m)	Uds.	Código	EAN	P.V.P. (€)
120	40	50	1	P-38196	0088381973908	59,00
	60			P-38205	0088381973915	48,00
	80			P-38211	0088381973922	42,00
	100			P-38227	0088381973939	39,00
	120			P-38233	0088381973946	39,00
	180			P-38249	0088381973953	39,00
	240			P-38255	0088381973960	39,00
	320			P-38261	0088381973977	39,00
	400			P-38277	0088381973984	39,00

**Bases para lijadoras orbitales**



158324-9



158326-5



158325-7



140441-9

Modelo	Tipo	Medida	Uds.	Código	EAN	P.V.P. (€)
BO4556 BO4565 BO4566	Cuadrada Goma *	112 x 102	1	158324-9	0088381413596	3,40
	Triangular Velcro	112 x 190	1	158325-7	3240890999597	8,95
	Rectangular Velcro	100 x 164	1	158326-5	3240890999580	7,80
BO3700 BO3711	Goma	93 x 185	1	140441-9	-	4,75
	Velcro	93 x 185	1	194930-6	0088381355759	15,40
BO4900V BO4901	Goma	115 x 229	1	193523-6	0088381164719	16,70
	Velcro	115 x 229	1	193521-0	0088381164702	31,20
9046	Velcro	115 x 229	1	162172-0	3240890063304	40,95

\* Para cambiar la base de goma de BO4556 a base de velcro triangular o rectangular es necesario utilizar base 450068-0.  
\*\* Esta base se considera accesorios.

**Lijadoras rotorbitales**

**Lijas para BO5040 / BO5041 / DBO180**

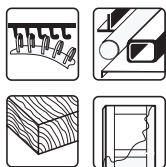

- Lija de grano semiabierto de óxido de aluminio, con recubrimiento de resinas fenólicas.
- Ideal para trabajos en madera, plástico, metal en planchas, maderas barnizadas y metales pintados.
- Perforaciones 8.

Ø (mm)	Grano	Uds.	Código	EAN	P.V.P. (€)
125	40	10	P-43533	0088381971409	5,50
	60		P-43549	0088381971416	5,20
	80		P-43555	0088381971423	5,00
	100		P-43561	0088381971430	5,00
	120		P-43577	0088381971447	5,00
	180		P-43583	0088381971454	5,00
	240		P-43599	0088381971461	5,00
	320		P-43608	0088381971478	4,70
	400		P-43614	0088381971485	4,70

**Lijas para BO6030 / BO6050**



- Lija de grano semiabierto de óxido de aluminio, con recubrimiento de resinas fenólicas.
- Ideal para trabajos en madera, plástico, metal en planchas, maderas barnizadas y metales pintados.
- Perforaciones 8.

Ø (mm)	Grano	Uds.	Código	EAN	P.V.P. (€)
150	40	10	P-31918	0088381960076	7,70
	60		P-31924	0088381960083	7,40
	80		P-31930	0088381960090	7,20
	100		P-31946	0088381960106	6,90
	120		P-31952	0088381960113	6,90
	150		P-31968	0088381960120	6,90
	180		P-31974	0088381960137	6,90
	220		P-31980	0088381960144	6,90
	240		P-31996	0088381960151	6,90
	320		P-32007	0088381960168	6,90
	400		P-32013	0088381960175	6,90

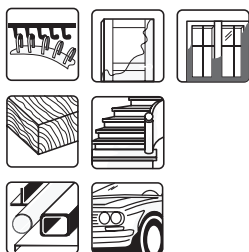

- Especial pintura.
- Excelente rendimiento en trabajos de automoción.
- Recubrimiento antiestático que previene atascos en la lija para un acabado más fino.
- Perforaciones 8.

Ø (mm)	Grano	Uds.	Código	EAN	P.V.P. (€)
125	40	10	P-33342	0088381961509	5,00
	60		P-33358	0088381961516	4,70
	80		P-33364	0088381961523	4,40
	100		P-33370	0088381961530	4,40
	120		P-33386	0088381961547	4,40
	180		P-33392	0088381961554	4,40
	240		P-33401	0088381961561	4,40
	320		P-33417	0088381961578	4,40
	400		P-33423	0088381961585	4,40

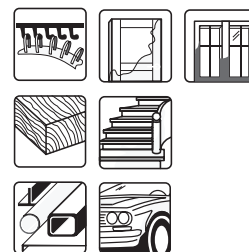
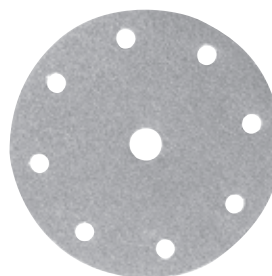

- Especial pintura.
- Excelente rendimiento en trabajos de automoción.
- Recubrimiento antiestático que previene atascos en la lija para un acabado más fino.
- Perforaciones 8.

Ø (mm)	Grano	Uds.	Código	EAN	P.V.P. (€)
150	40	10	P-37839	0088381973540	7,40
	60		P-37845	0088381973557	6,90
	80		P-37851	0088381973564	6,60
	100		P-37867	0088381973571	6,30
	120		P-37873	0088381973588	6,30
	150		P-37889	0088381973595	6,30
	180		P-37895	0088381973601	6,30
	220		P-37904	0088381973618	6,30
	240		P-37910	0088381973625	6,30
	320		P-37926	0088381973632	6,30
	400		P-37932	0088381973649	6,30



**Lijadoras roborbitales y de disco**

**Cajas de discos de velcro perforados de 150mm**

- Gama de lijas de óxido de aluminio para lijadoras roborbitales de 150mm.
- Paquetes de 50 y 100 unidades.
- Ideales para usuarios con gran consumo de lijas.
- Perfectas para el acabado en fibra de vidrio, madera, metal y chapa de automóvil.
- Perforaciones 8+6.



Ø (mm)	Grano	Uds.	Código	EAN	P.V.P. (€)
150	40	50	B-39300	0088381434041	31,00
	60		B-39316	0088381434058	29,00
	80	100	B-39322	0088381434065	51,00
	100		B-39338	0088381434072	48,00
	120		B-39344	0088381434089	46,00
	240		B-39350	0088381434096	45,00
	320		B-39366	0088381434102	45,00
	360		B-39372	0088381434119	45,00
	400		B-39388	0088381434126	45,00
	500		B-39394	0088381434133	45,00
600	B-39403	0088381434140	45,00		
800	B-39419	0088381434157	45,00		
1.000	B-39425	0088381434164	45,00		

**Lijas para jirafa de 225mm**

- Discos especiales para trabajos en tabiquería seca.
- Grano cerámico con resina.
- Recubrimiento especial, previene que se emboce y evita el desgaste.
- Más durabilidad que un disco abrasivo.

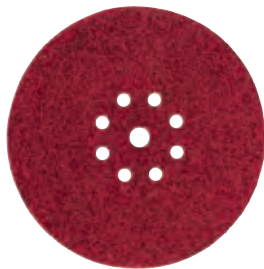

Ø (mm)	Grano	Uds.	Código	EAN	P.V.P. (€)
225	40	25	B-68389	0088381545891	34,00
	80		B-68395	0088381545907	33,00
	120		B-68404	0088381545914	29,00
	180		B-68410	0088381545921	29,00
	320		B-68426	0088381545938	29,00

**Lijas de discos 115mm / 125mm / 180mm**

- Discos de fibra excelentes para quitar barnices y pinturas en madera y metal, así como repasos en soldaduras.



Ø (mm)	Grano	Uds.	Código	EAN	P.V.P. (€)
115	24	5	P-00860	0088381918787	4,50
	40		P-00882	0088381918800	5,90
	60		P-00907	0088381918824	5,90
	80		P-00913	0088381918831	5,90
	120		P-00935	0088381918848	6,20
125	24		P-00957	0088381922203	5,40
	40		P-00979	0088381922227	6,70
	60		P-00985	0088381922234	6,70
	80		P-00991	0088381922241	7,00
	100		P-01002	0088381922258	7,30
180	120	P-01018	0088381922265	7,30	
	24	P-01030	0088381918879	8,50	
	40	P-01052	0088381918893	8,70	
	60	P-01074	0088381918916	8,70	
	80	P-01080	0088381918923	8,70	
	100	P-01096	0088381918930	8,10	
	120	P-01105	0088381918947	8,10	

**Lijas para lijadoras de disco 180mm**

- Lija de óxido de aluminio de grano abierto con recubrimiento de resina y pegamento con base de látex.
- Excelente rendimiento en trabajos de automoción.
- Perfecta para los trabajos en maderas sin tratar, maderas barnizadas, carrocería.
- Especial para el lijado de pintura.

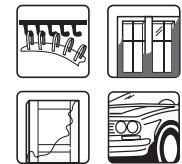

Ø (mm)	Grano	Uds.	Código	EAN	P.V.P. (€)
180	40	10	P-33439	0088381961592	11,00
	60		P-38037	0088381973748	9,10
	80		P-33445	0088381961608	8,60
	100		P-38043	0088381973755	8,20
	120		P-33451	0088381961615	8,20
	240		P-38059	0088381973762	8,20
	320	P-38065	0088381973779	8,20	

**Accesorios de corte**

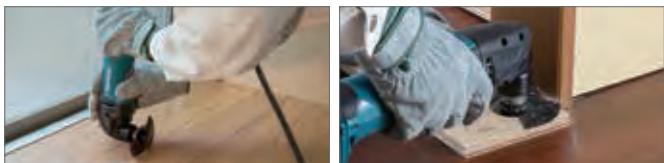

**Cuchilla de corte segmentada 85 STARLOCK**

**TMA064**

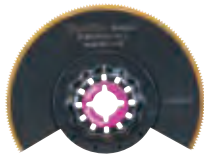

- Metales no ferrosos, FRP, PVC.
- Adecuado para esquinas.
- Corte por inmersión en placas de yeso o de fibra de cemento.
- Realizar cajeados en fibra de vidrio (PRFV) / epoxy

Ø (mm)	Material / Indicado para	Uds.	Código	EAN	P.V.P. (€)
85	BiM - TIN / Multimaterial	1	B-64973	0088381536479	25,00

**Cuchilla de corte segmentada 100 STARLOCK**

**TMA046**



- Madera y metal.
- Indicado para cortes profundos a ras.
- Marcos de puertas.
- Parquet / suelo laminado.

Ø (mm)	Material / Indicado para	Uds.	Código	EAN	P.V.P. (€)
100	BiM / Madera y Metal	1	B-64808	0088381536301	26,00

**Cuchilla de corte segmentada 85 STARLOCK**

**TMA049**



- Cortes de inmersión en madera sólida.
- Indicado para cortes a ras.
- Tubo de PVC.

Ø (mm)	Material / Indicado para	Uds.	Código	EAN	P.V.P. (€)
85	HCS / Madera	1	B-64836	0088381536332	15,40

**Cuchilla de corte segmentada 85 STARLOCK**

**TMA045**



- Madera y metal.
- Indicado para cortes profundos a ras.
- Marcos de puertas.
- Parquet / suelo laminado.

Ø (mm)	Material / Indicado para	Uds.	Código	EAN	P.V.P. (€)
85	BiM / Madera y Metal	1	B-64799	0088381536295	18,20

**Accesorios de corte de inmersión**



**Cuchilla de inmersión 65 STARLOCK**

**TMA048**



- Madera y clavos.
- Marcos de puerta.
- Cortes por inmersión en paneles laminados.

Tamaño (mm)	Material / Indicado para	Uds.	Código	EAN	P.V.P. (€)
65 x 40	BiM / Madera y Metal	1	B-64820	0088381536325	19,30

**Cuchilla de inmersión 65 STARLOCK**

**TMA052**



- Madera y metal.
- Indicado para corte a ras.
- Parquet / suelo laminado.
- Cortes de inmersión en madera.

Tamaño (mm)	Material / Indicado para	Uds.	Código	EAN	P.V.P. (€)
65 x 40	HCS / Madera	1	B-64864	0088381536363	14,30

**Cuchilla de inmersión 32 STARLOCK**

**TMA047**



- Madera y metal.
- Adecuado para corte por inmersión precisa.
- Corte por inmersión en madera dura.

Tamaño (mm)	Material / Indicado para	Uds.	Código	EAN	P.V.P. (€)
32 x 50	BiM / Madera y Metal	1	B-64814	0088381536318	13,80
32 x 50	BiM / Madera y Metal (20 Uds.)	20	B-64814-20	0088381541213	226,00

**Cuchilla de inmersión 32 STARLOCK**

**TMA051**



- Cajeados en muebles.
- Cortes profundos en madera blanda.
- Cortes de inmersión en madera blanda.

Tamaño (mm)	Material / Indicado para	Uds.	Código	EAN	P.V.P. (€)
32 x 50	HCS / Madera	1	B-64858	0088381536356	12,10
32 x 50	HCS / Madera (20 Uds.)	20	B-64858-20	0088381541220	156,00

**Accesorios de corte de inmersión**

**Cuchilla de inmersión 65**



**TMA055**



- Cajeados en muebles.
- Cortes al ras.
- Corte de inmersión en paneles laminados o madera dura.

Tamaño (mm)	Material / Indicado para	Uds.	Código	EAN	P.V.P. (€)
65 x 40	BiM / Madera	1	B-64892	0088381536394	18,70

**Cuchilla de inmersión 65**



**TMA056**



- Cajeados en muebles.
- Cortes al ras.
- Corte de inmersión en paneles laminados o madera.

Tamaño (mm)	Material / Indicado para	Uds.	Código	EAN	P.V.P. (€)
65 x 40	HCS / Madera	1	B-64901	0088381536400	15,40

**Cuchilla de inmersión 32**



**TMA053**



- Madera dura.
- Cajeados en muebles.
- Cortes de inmersión en madera dura y paneles laminados.

Tamaño (mm)	Material / Indicado para	Uds.	Código	EAN	P.V.P. (€)
32 x 50	BiM / Madera	1	B-64870	0088381536370	12,40
32 X 50	BiM / Madera	5	B-64870-5	0088381536684	60,00
32 x 50	BiM / Madera	20	B-64870-20	0088381541237	226,00

**Cuchilla de inmersión 24**



**TMA050**



- Cajeados en muebles.
- Cortes al ras en madera. Cortes profundos en madera blanda.
- Cortes de inmersión en madera blanda.

Tamaño (mm)	Material / Indicado para	Uds.	Código	EAN	P.V.P. (€)
24 x 50	HCS / Madera	1	B-64842	0088381536349	8,60
24 x 50	HCS / Madera	5	B-64842-5	0088381588409	42,00



**Cuchilla de inmersión 20**



**TMA058**



- Metal. Adecuado para corte al ras en clavos o tubo de cobre.
- Cortes en zócalos.

Tamaño (mm)	Material / Indicado para	Uds.	Código	EAN	P.V.P. (€)
20 x 30	BiM / Metal	1	B-64923	0088381536424	9,40

**Cuchilla de inmersión 32**



**TMA061**



- Corte de acero inoxidable.
- Adecuado para corte al ras en tornillos y clavos endurecidos.
- Corte de fibra de vidrio.

Tamaño (mm)	Material / Indicado para	Uds.	Código	EAN	P.V.P. (€)
32 x 40	TC / HM, Metal	1	B-64951	0088381536455	25,00

**Cuchilla de inmersión 32**



**TMA059**



- Cortes en zócalos.
- Metal. Adecuado para corte al ras en clavos o tubo de cobre.

Tamaño (mm)	Material / Indicado para	Uds.	Código	EAN	P.V.P. (€)
32 x 50	BiM / Metal	1	B-64939	0088381536431	12,10

**Cuchilla de inmersión 10**



**TMA057**



- Metal. Adecuado para corte al ras en clavos.
- Cortes de inmersión en placas de yeso.
- Cortes en zócalos.

Tamaño (mm)	Material / Indicado para	Uds.	Código	EAN	P.V.P. (€)
10 x 30	HCS / Madera	1	B-64917	0088381536417	8,20



**Cuchilla de inmersión 20**



**TMA060**



- Corte de acero inoxidable.
- Adecuado para corte al ras en tornillos y clavos endurecidos.
- Corte de fibra de vidrio.

Tamaño (mm)	Material / Indicado para	Uds.	Código	EAN	P.V.P. (€)
20 x 40	TC / HM, Metal	1	B-64945	0088381536448	21,00

**Cuchilla de inmersión 32**



**TMA054**



- Cajeados en muebles.
- Cortes de inmersión en madera.

Tamaño (mm)	Material / Indicado para	Uds.	Código	EAN	P.V.P. (€)
32 x 50	HCS / Madera	1	B-64886	0088381536387	12,10

**Rascadores**



**Rascador rígido 52**



**TMA065**



- Retirar restos de moqueta, lechada...
- Eliminación de residuos: Adhesivo, mortero y hormigón.

Tamaño (mm)	Material / Indicado para	Uds.	Código	EAN	P.V.P. (€)
52 x 26	HCS	1	B-64989	0088381536486	9,60

**Rascador flexible 52**



**TMA066**



- Eliminación de residuos de pintura.
- Retirar juntas de silicona.
- Eliminación de residuos de adhesivos de alfombras.

Tamaño (mm)	Material / Indicado para	Uds.	Código	EAN	P.V.P. (€)
52 x 40	HCS	1	B-64995	0088381536493	9,90

**Cuchillas de corte**



**Cuchilla segmentada de sierra 100**



**TMA063**



- Ideal para materiales de aislamiento.
- Corte de poliestireno a ras.
- Cortar materiales blandos (moqueta, cuero...)

Ø (mm)	Material / Indicado para	Uds.	Código	EAN	P.V.P. (€)
100	BiM	1	B-64967	0088381536462	25,00

**Cuchilla de corte 28**



**TMA067**



- Cortar juntas de expansión blandas.
- Retirar silicona de ventanas.
- Recortar material aislante.

Tamaño (mm)	Material / Indicado para	Uds.	Código	EAN	P.V.P. (€)
28 x 40	HCS	1	B-65006	0088381536509	17,10

**Cuchilla universal multicorte 11**



**TMA068**



- Cortar juntas de expansión blandas.
- Retirar silicona de ventanas.
- Recortar material aislante.

Tamaño (mm)	Material / Indicado para	Uds.s	Código	EAN	P.V.P. (€)
11 x 24	HCS	1	B-65012	0088381536516	18,20



**Limpieza y corte**



**Cuchilla de limpieza HM 32**



**TMA075**



Corte por inmersión y raspado en fibra de vidrio.

- Eliminar las lechadas en esquinas estrechas o juntas de cemento.

Tamaño (mm)	Material / Indicado para	Uds.	Código	EAN	P.V.P. (€)
32 x 30	TC / HM Grano 50	1	B-65084	0088381536585	25,00

**Cuchilla de limpieza HM 32**



**TMA076**



- Lijado de barniz o pinturas en zonas de difícil acceso.
- Lijado de madera, compuesto de madera-plástico y epoxy.

Tamaño (mm)	Material / Indicado para	Uds.	Código	EAN	P.V.P. (€)
32 x 50	TC / HM Grano 40	1	B-65090	0088381536592	22,00

**Cuchilla de limpieza HM 32**



**TMA077**



- Lijado de barniz o pinturas en zonas de difícil acceso.
- Lijado de madera, compuesto de madera-plástico y epoxy.

Tamaño (mm)	Material / Indicado para	Uds.	Código	EAN	P.V.P. (€)
32 x 50	TC / HM Grano 100	1	B-65109	0088381536608	22,00

**Cuchilla de limpieza HM**



**TMA074**



- Para levantar mortero.
- Limpiar las juntas de los azulejos de suelo.
- Limpieza de juntas de esquinas con la punta de carburo de tungsteno.

Tamaño (mm)	Material / Indicado para	Uds.	Código	EAN	P.V.P. (€)
70	TC / HM Grano 40	1	B-65078	0088381536578	39,00

**Cuchilla de limpieza HM 85**



**TMA069**



- Limpieza de juntas en pared y suelo.
- Pequeños cortes en azulejo blando.
- Realizar rozas en hormigón poroso para cables y tuberías.

Ø (mm)	Material / Indicado para	Uds.	Código	EAN	P.V.P. (€)
85	TC / HM Grano 40	1	B-65028	0088381536523	28,00

**Cuchilla de corte y limpieza diamante segmentada HM 85**



**TMA070**



- Pequeños cortes en azulejo blando.
- Realizar rozas en epoxy, fibra de vidrio, pvc, porcelánico.

Ø (mm)	Material / Indicado para	Uds.	Código	EAN	P.V.P. (€)
85	TC / HM Grano 40	1	B-65034	0088381536530	45,00

**Cuchilla de corte y limpieza segmentada HM 70**



**TMA071**



- Limpieza de juntas en pared y suelo.
- Pequeños cortes en azulejo blando.
- Realizar rozas en hormigón poroso para cables y tuberías.

Ø (mm)	Material / Indicado para	Uds.	Código	EAN	P.V.P. (€)
70	TC / HM Grano 50	1	B-65040	0088381536547	25,00

**Cuchilla de corte y limpieza segmentada HM 85**



**TMA072**



- Limpieza de juntas en pared y suelo.
- Pequeños cortes en azulejo blando.
- Realizar rozas en hormigón poroso.

Ø (mm)	Material / Indicado para	Uds.	Código	EAN	P.V.P. (€)
85	TC / HM Grano 40	1	B-65056	0088381536554	24,00

**Cuchilla de limpieza**

**Cuchilla de limpieza TC HM 78 STARLOCK**

**TMA073**



- Retirar mortero o cola de azulejo.
- Limpiar adhesivo de las alfombras.

Tamaño (mm)	Material / Indicado para	Uds.	Código	EAN	P.V.P. (€)
78	TC / HM Grano 20	1	B-65062	0088381536561	24,00

**Plato de lija 93**



**TMA078**



Tamaño (mm)	Material / Indicado para	Uds.	Código	EAN	P.V.P. (€)
93	Velcro	1	B-65115	0088381536615	12,10

**Set de cuchillas**

**Set de cuchillas de inmersión**

**TMA045** Cuchilla de corte segmentada 85

**TMA047** Cuchilla de inmersión 32

**TMA053** Cuchilla de inmersión 32

**TMA058** Cuchilla de inmersión 20



Tamaño (mm)	Material / Indicado para	Uds.	Código	EAN	P.V.P. (€)
-	Cortes por inmersión	4	B-67480	0088381541145	48,00

**Set de cuchillas para azulejo**

**TMA058** Cuchilla de inmersión 20

**TMA065** Rascador rígido 52

**TMA069** Cuchilla de limpieza HM 85

**TMA073** Cuchilla de limpieza TC HM 78



Tamaño (mm)	Material / Indicado para	Uds.	Código	EAN	P.V.P. (€)
-	Azulejo	4	B-67496	0088381541152	58,00



































**Tabla de aplicación - Lijas para multiherramienta**

		Grano	Pintura	Barniz	Lacas	Yeso	Madera	Madera blanda	Madera dura	Contrachapado de madera	Aglomerado / MDF	Fibra de vidrio / Plásticos	Metal	Acero	Piedra	Mármol	Granito	Vidrio	Metacrilato		
Madera / long life	Grueso	60																			
		80																			
	Medio	100	-	-	-	-	✓✓	✓✓	✓✓	✓✓	✓	✓✓	✓	-	-	-	-	-	-	-	
		120																			
		180																			
Fino	240																				
Madera	Grueso	60																			
		80																			
	Medio	100	-	-	-	-	✓✓	✓	✓✓	✓✓	✓	-	-	-	-	-	-	-	-	-	
		120																			
		150																			
Fino	180																				
	240																				
Pintura	Grueso	60																			
		80																			
	Medio	100	✓✓	✓✓	✓✓	✓✓	-	-	✓	-	-	✓	✓	-	-	-	-	-	-	-	
		120																			
		240																			
Fino	320																				
Piedra	Medio	120																			
		240	✓	✓✓	-	-	-	-	-	-	✓	-	-	✓	✓	✓	✓	✓	✓		
	Fino	400																			
		600																			
	Muy fino	1200																			



**Tipos de discos para sierras circulares, ingletadoras y sierras de incisión**

			85mm	136mm	165mm	185mm	190mm	210mm	235mm	270mm	355mm
<b>MAKFORCE</b>			-	-	160mm	170mm	180mm	230mm	✓	✓	✓
<b>SPECIALIZED REFORZADO</b>			-	-	✓	✓	✓	✓	✓	✓	✓
<b>MFORCE</b>			-	-	✓	✓	-	-	✓	-	-
<b>SPECIALIZED STANDARD</b>			-	-	✓	✓	-	✓	✓	-	-
<b>SPECIALIZED STANDARD economy</b>			-	-	✓	✓	✓	-	✓	-	-
<b>SPECIALIZED ALUMINIO</b>			-	-	160mm	-	✓	✓	✓	-	360mm
<b>SPECIALIZED CONSTRUCCION</b>			-	-	-	-	✓	✓	✓	-	-
<b>SPECIALIZED PANEL SANDWICH</b>			-	-	✓	-	-	-	✓	✓	✓
<b>SPECIALIZED MAQUINAS DE BATERIA</b>			✓	✓	✓	-	✓	-	✓	-	-
<b>SPECIALIZED INCISION</b>			-	-	160mm	-	-	-	-	-	-

			136mm	165mm	190mm	216mm	250mm	260mm	300mm	305mm	315mm
<b>MAKBLADE PLUS</b>			-	-	✓	-	✓	-	-	-	-
<b>MAKBLADE</b>			-	-	✓	✓	✓	255mm	260mm	✓	-
<b>SPECIALIZED ALUMINIO</b>			-	-	✓	✓	-	✓	-	✓	350mm
<b>SPECIALIZED S. MESA</b>			-	-	-	210 mm	-	✓	-	-	✓
<b>SPECIALIZED S. MESA</b>			-	-	-	-	-	✓	✓	-	350mm
<b>SPECIALIZED LAMINADOS</b>			✓	✓	✓	✓	-	✓	-	✓	-

**Discos de sierra para sierras circulares**

**Discos Makforce**



Una extensa selección de discos para todas las marcas y modelos de sierras circulares portátiles.

Amplia gama de medidas, desde 160mm hasta 355mm y de número de dientes desde 12 hasta 60. La gama abarca un gran número de aplicaciones desde corte grueso y corte transversal a corte fino y longitudinal.

- La estructura del disco es de acero tensionado de precisión, absorbe los impactos sin deformarse.
- Carburo de tungsteno de alta calidad y bajo desgaste para una larga vida de la sierra.
- Afilado perfecto para cortes más precisos.
- Corte fino, con menos viruta y menos esfuerzo en el motor.

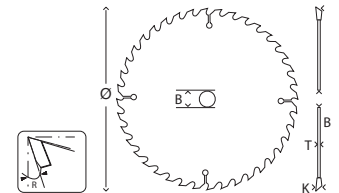

**Ø 165mm DHS660 - DHS661 - DHS680 - DSS610 - HS6100 - HS6601**

Ø ext. (mm)	Ø int. (mm)	K (mm)	T (mm)	Nº dientes	R	Tipo de diente	Reducción	Código	EAN	P.V.P (€)
160	20	2,4	1,5	16	20°	ATB	15,88	B-32091	0088381420907	20,00
160	20	2,4	1,5	24	20°	ATB	15,88	B-32203	0088381421010	27,00
160	20	2,4	1,5	40	20°	ATB	15,88	B-32297	0088381421102	31,00
165	20	2,4	1,5	10	20°	FTG	-	B-32100	0088381420914	24,00
170	30	2,4	1,5	16	20°	ATB	15,88	B-32122	0088381420938	22,00
170	30	2,4	1,5	24	20°	ATB	15,88	B-32225	0088381421034	25,00
170	30	2,4	1,5	40	20°	ATB	15,88	B-32312	0088381421126	33,25

**Ø 190mm DHS710 - DHS782 - DHS783 - HS7601 - HS7100 - HS7101 - M5802B - HS004G**

180	20	2,4	1,5	16	20°	ATB	-	B-08187	0088381336178	21,00
180	20	2,4	1,5	24	20°	ATB	-	B-08327	0088381336314	27,50
190	30	2	1,4	12	20°	FTG	20/15,88	B-32144	0088381420952	25,00
190	30	2,2	1,4	24	20°	ATB	20/15,88	B-32247	0088381421058	26,50
190	30	2,2	1,4	40	20°	ATB	20/15,88	B-32340	0088381421157	34,00
190	30	2,2	1,4	60	15°	ATAF	20/15,88	B-32390	0088381421201	37,00

**Ø 210mm 5008MG**

210	30	2,4	1,6	16	20°	ATB	-	B-32150	0088381420969	26,50
210	30	2,4	1,6	24	20°	ATB	-	B-32253	0088381421065	34,00
210	30	2,4	1,6	40	20°	ATB	-	B-32356	0088381421164	36,00

**Ø 235mm 5903R - 5903RK - DHS900 - HS009G**

235	30	2,3	1,6	20	20°	ATB	-	B-32269	0088381421072	27,00
235	30	2,6	1,6	40	20°	ATB	-	B-32362	0088381421171	38,00
235	30	2,8	1,8	60	15°	ATAF	-	B-32415	0088381421225	39,00

**Ø 270mm 5103R - HS0600 - HS011G**

270	30	2,6	1,8	24	20°	ATB	-	B-32172	0088381420983	45,00
270	30	2,6	1,6	40	20°	ATB	-	B-32378	0088381421188	51,00
270	30	2,8	1,8	60	15°	ATAF	-	B-32409	0088381421218	61,00

**Ø 355mm 5143R**

355	30	3,0	2,2	24	20°	ATB	-	B-32188	0088381420990	60,00
355	30	3,0	2,2	40	20°	ATB	-	B-32281	0088381421096	71,00
355	30	3,0	2,2	60	20°	ATB	-	B-32384	0088381421195	78,00



Discos de sierra para sierras circulares

Discos Specialized Reforzado



Diseñados para sierras circulares de Makita y otros fabricantes de sierras, los dientes reforzados o "dientes embutidos" son especialmente resistentes y con bajo desgaste. Para cortes fáciles en maderas con nudos. Diseñado para evitar que salten los dientes cuando se corten clavos en madera accidentalmente.

Especialmente apropiado para la recuperación de madera y de trabajos de demolición.

- Corte en madera con clavos accidentales y nudos.
- Extremadamente resistente y de bajo desgaste.
- Aumentan la vida de la sierra y la productividad.
- Corte fino, con menos viruta y menos esfuerzo en el motor.

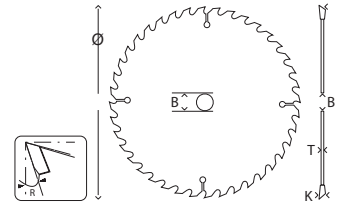

**Ø 165mm DHS660 - DHS661 - DHS680 - DSS610 - HS6100 - HS6601**

Ø ext. (mm)	Ø int. (mm)	K (mm)	T (mm)	Nº dientes	R	Tipo de diente	Reducción	Código	EAN	P.V.P (€)
165	20	2	1,25	16	23°	ATB Reforzado	-	B-33037	0088381421904	32,50
165	20	2	1,25	24	23°	ATB Reforzado	-	B-33093	0088381421966	38,00
165	20	2	1,25	40	18°	ATB Reforzado	-	B-33168	0088381422031	41,50

**Ø 190mm DHS710 - DHS782 - DHS783 - HS7601 - HS7100 - HS7101 - M5802B - HS004G**

185	30	2	1,25	16	25°	ATB Reforzado	-	B-33043	0088381421911	24,00
185	30	2	1,25	40	25°	ATB Reforzado	-	B-33174	0088381422048	35,00
190	30	2	1,25	16	23°	ATB Reforzado	-	B-33059	0088381421928	25,50
190	30	2	1,25	24	23°	ATB Reforzado	-	B-33118	0088381421980	31,00
190	30	2	1,25	40	23°	ATB Reforzado	-	B-33180	0088381422055	41,00

**Ø 235mm 5903R - 5903RK - DHS900 - HS009G**

235	30	2,3	1,6	24	23°	ATB Reforzado	-	B-33130	0088381422000	33,50
235	30	2,3	1,6	48	18°	ATB Reforzado	-	B-33196	0088381422062	62,00

**Ø 270mm 5103R - HS0600 - HS011G**

270	30	2,6	1,8	40	18°	ATB Reforzado	-	B-33205	0088381422079	85,00
270	30	2,6	1,8	60	18°	ATB Reforzado	-	B-33211	0088381422086	96,00

**Ø 355mm 5143R**

355	30	3	2,2	24	23°	ATB Reforzado	-	B-33087	0088381421959	95,80
355	30	3	2,2	60	18°	ATB Reforzado	-	B-33227	0088381422093	129,50





**Discos de sierra para sierras circulares**

**Discos MForce**



Diseño avanzado y revolucionario para sierras circulares.

El diente con doble cara biselada tiene un corte fino y el diseño en "M" hace el efecto del doble diente.

Mayor superficie de corte del diente se traduce en una duración mayor que los discos tradicionales. Un corte y un diente estrecho reduce la fricción consiguiendo así un menor aumento de la corriente, protegiendo el motor de su sierra. Corte en madera con clavos accidentales y nudos.

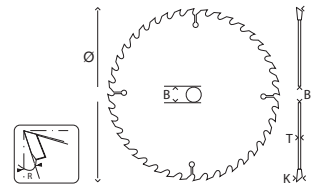

- Acabado perfecto, ya que el número de dientes en M se multiplica por 2.
- Corte agresivo.
- Área de trabajo más grande.
- Más duradero.



Ø ext. (mm)	Ø int. (mm)	K (mm)	T (mm)	Nº dientes	R	Tipo de diente	Reducción	Código	EAN	P.V.P (€)
165	20	2	1,2	16	15°	M-Force	-	B-31930	0088381420747	17,00
165	20	2	1,2	24	15°	M-Force	-	B-32007	0088381420815	19,20

**Ø 190mm DHS710 - DHS782 - DHS783 - HS7601 - HS7100 - HS7101 - M5802B - HS004G**

185	30	2	1,2	24	15°	M-Force	20/15,88	B-32035	0088381420846	22,00
-----	----	---	-----	----	-----	---------	----------	---------	---------------	-------

**Ø 235mm 5903R - 5903RK - DHS900 - HS009G**

235	30	2,3	1,6	20	15°	M-Force	-	B-31996	0088381420808	30,00
235	30	2,3	1,6	40	15°	M-Force	25/15,88	B-32085	0088381420891	37,50

**Discos Specialized Standard**



Diseñados para sierras circulares Makita y otros fabricantes de sierras.

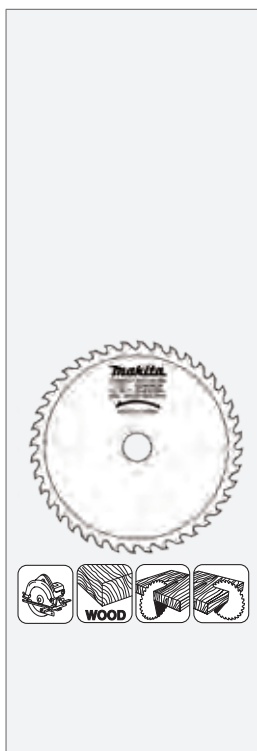

**Ø 165mm DHS660 - DHS661 - DHS680 - DSS610 - HS6100 - HS6601**

Ø ext. (mm)	Ø int. (mm)	K (mm)	T (mm)	Nº dientes	R	Tipo de diente	Reducción	Código	EAN	P.V.P (€)
165	20	2,4	1,5	10	20°	ATB	-	D-03327	0088381173667	12,30
165	20	2,0	1,5	16	20°	ATB	-	D-09628	0088381184816	13,50
165	20	2,4	1,5	24	20°	ATB	-	D-03333	0088381173674	14,70
165	20	2,4	1,5	40	18°	ATB	-	D-03349	0088381173681	17,80

**Ø 190mm DHS710 - DHS782 - DHS783 - HS7601 - HS7100 - HS7101 - M5802B - HS004G**

185	30	1,8	1,2	16	20°	ATB	20	D-03903	0088381174336	13,50
185	30	2,0	1,2	20	20°	ATB	30/20	D-09634	0088381184823	14,70
185	30	1,8	1,2	40	18°	ATB	20	D-03919	0088381174343	16,50

**Ø 210mm 5008MG**

210	30	2,0		24	20°	ATB	-	D-29050	0088381343466	25,00
-----	----	-----	--	----	-----	-----	---	---------	---------------	-------

**Ø 235mm 5903R - 5903RK - DHS900 - HS009G**

235	30	2,3	1,6	20	20°	ATB	25	D-03925	0088381174350	21,00
235	30	2,3	1,6	48	18°	ATB	25	D-03931	0088381174367	25,50
235	30	2,3	1,6	60	15°	ATB	25	D-09640	0088381184830	31,00

Discos de sierra para sierras circulares

Discos Specialized Standard Economy



- Diseñados para sierras circulares Makita y otros fabricantes de sierras.
- Cortes en maderas blandas.
- Excelente calidad / precio.

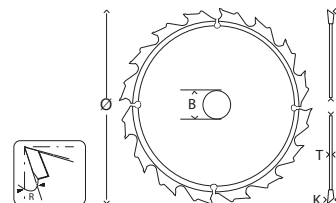

**Ø 165mm DHS660 - DHS661 - DHS680 - DSS610 - HS6100 - HS6601**

Ø ext. (mm)	Ø int. (mm)	K (mm)	T (mm)	Nº dientes	R	Tipo de diente	Reducción	Código	EAN	P.V.P (€)
165	20	2,0	1,2	16	12°	ATB	-	D-52554	0088381444422	7,70
165	20	2,0	1,2	24	12°	ATB	-	D-52560	0088381444439	9,00
165	20	2,0	1,2	40	12°	ATB	-	D-52576	0088381444446	11,00

**Ø 190mm DHS710 - DHS782 - DHS783 - HS7601 - HS7100 - HS7101 - M5802B - HS004G**

185	30	2,2	1,4	16	18°	ATB	-	D-52582	0088381444453	9,70
185	30	2,2	1,4	24	15°	ATB	-	D-52598	0088381444460	11,00
185	30	2,2	1,4	40	14°	ATB	-	D-52607	0088381444477	12,30

**Ø 190mm DHS710 - DHS782 - DHS783 - HS7601 - HS7100 - HS7101 - M5802B - HS004G**

190	30	2,2	1,4	24	15°	ATB	-	D-64951	0088381533096	11,30
190	30	2,2	1,4	40	15°	ATB	-	D-64967	0088381533102	12,90
190	30	2,0	1,4	40	18°	ATB	-	D-64973	0088381533119	15,40

**Ø 210mm - 5008MG**

210	30	2,5	1,6	24	15°	ATB	-	D-72291	0088381569026	14,00
210	30	2,5	1,6	40	15°	ATB	-	D-72300	0088381569033	15,20

**Ø 235mm 5903R - 5903RK - DHS900 - HS009G**

235	30	2,5	1,6	20	14°	ATB	-	D-52613	0088381444484	16,70
235	30	2,5	1,6	40	12°	ATB	-	D-52629	0088381444491	19,40
235	30	2,5	1,6	60	12°	ATB	-	D-52635	0088381444507	22,00



Makita

Discos de sierra para sierras circulares

Discos Specialized Aluminio



Amplia gama de discos para sierras circulares con un excelente rendimiento de corte en aluminio, latón, bronce y otros metales no ferrosos. Los discos también son válidos para trabajar en plásticos y maderas laminadas. Aplicar cera de discos en la zona del diente frecuentemente para prevenir la acumulación de viruta en los dientes cuando cortemos metales no ferrosos.

- La estructura del disco es de acero tensionado de precisión para mayor rigidez y cortes más rectos.
- Excelente calidad de corte en materiales no ferrosos.
- Perfecta realización del corte en suelos laminados.

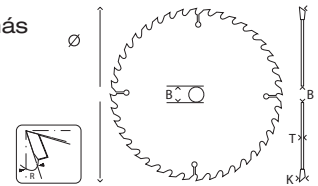

Ø 165mm DHS680 - DHS660 - DHS661 - DSS610 - HS6601 - HS6100											
Ø ext. (mm)	Ø int. (mm)	K (mm)	T (mm)	Nº dientes	R	Tipo de diente	Reducción	Código	EAN	P.V.P (€)	
160	20	2,4	1,8	60	0°	TCG	-	B-33233	0088381422109	42,00	
Ø 190mm DHS710 - DHS782 - DHS783 - HS7601 - HS7100 - HS7101 - M5802B - HS004G											
190	30	2,4	1,8	60	0°	TCG	20/15,88	B-33261	0088381422130	60,00	
Ø 210mm 5008MG											
210	30	2,8	2	54	-5°	TCG	25	B-33548	0088381422437	65,00	
Ø 235mm 5903R - 5903RK - DHS900 - HS009G											
235	30	2,4	1,8	80	0°	TCG	-	B-33277	0088381422147	70,00	
Ø 350mm											
350	30	3,2	2,6	100	0°	TCG	-	B-33401	0088381422284	130,50	

Discos Specialized Construcción



Estos discos están indicados para maderas de construcción, maderas de encofrados, maderas con clavos, maderas prensadas, maderas con residuos de hormigón.

- El diente está embutido dentro del cuerpo del disco, para conseguir una gran resistencia.
- Los dientes pueden ser reafilados para un mayor aprovechamiento del disco.
- Gracias a su estructura reforzada conseguimos cortes rectos sin desviaciones sin necesidad de ninguna guía.

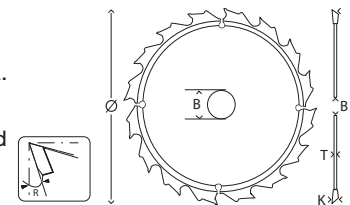

Ø 190mm DHS710 - DHS782 - DHS783 - HS7601 - HS7100 - HS7101 - M5802B - HS004G											
Ø ext. (mm)	Ø int. (mm)	K (mm)	T (mm)	Nº dientes	R	Tipo de diente	Reducción	Código	EAN	P.V.P (€)	
190	30	2,6	1,6	12	20°	FTG Reforzado	-	B-33554	0088381422444	28,00	
Ø 210mm 5008MG											
210	30	2,8	1,8	14	20°	FTG Reforzado	-	B-33766	0088381422659	29,50	
Ø 235mm 5903R - 5903RK - DHS900 - HS009G											
235	30	2,8	1,8	16	20°	FTG Reforzado	-	B-33560	0088381422451	41,50	



Discos de sierra para sierras circulares

Discos Specialized Panel Sandwich



Discos con diente de HM para el corte específico de panel sandwich.

Diente con forma triangular contrapuesto:

- Reduce la rebaba en la pieza.
- Evita la rotura del disco.
- Ranuras para evitar vibración y ruido.

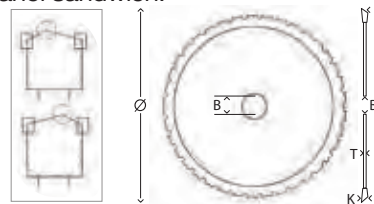

- Ideal para su utilización en nuestros modelos 5903R, 5104S, 5103R y 5143R.
- Larga duración. Muy buen acabado gracias al tipo de diente.



Ø 165mm DHS660 - DHS661 - DSS610 - DHS680 - HS6601 - HS6100										
Ø ext. (mm)	Ø int. (mm)	K (mm)	T (mm)	Nº dientes	R	Tipo de diente	Reducción	Código	EAN	P.V.P (€)
165	20	1,75	1,4	42	0°	SMTCG LaserSlit	-	B-63149	0088381529921	63,00
Ø 235mm 5903R - 5903RK - DHS900 - HS009G										
235	30	2,2	1,8	50	0°	SMTCG LaserSlit	-	B-33582	0088381422475	93,00
Ø 270mm 5103R - HS0600										
270	30	2,4	2	60	0°	SMTCG LaserSlit	-	B-33598	0088381422482	134,00
Ø 355mm 5143R										
355	30	2,6	2,2	80	0°	SMTCG LaserSlit	-	B-33607	0088381422499	162,00

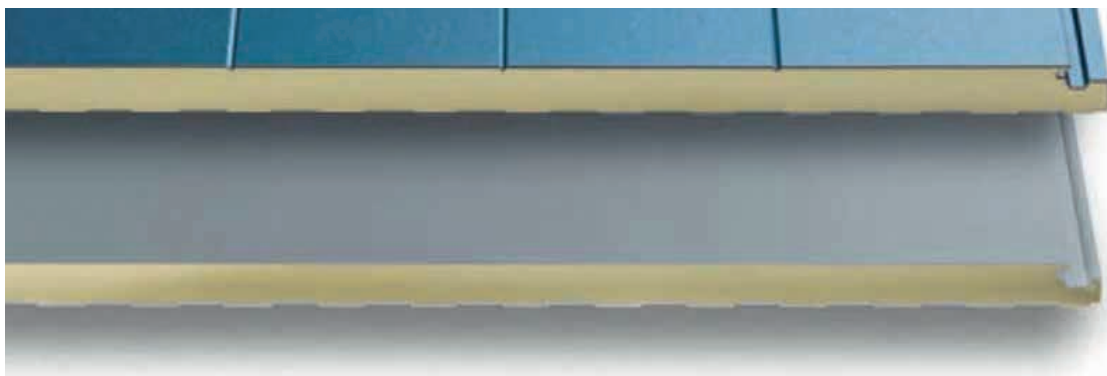

Discos Specialized Batería



Los discos de calidad superior están hechos especialmente para las sierras a batería.

Discos para cortar madera, ahora disponibles para las sierras circulares a batería más populares.

“Todas con la calidad Makita”.

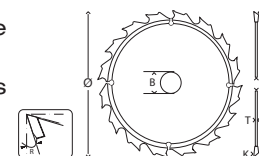

**Ø 85mm HS301D**

Ø ext. (mm)	Ø int. (mm)	K (mm)	T (mm)	N° dientes	R	Tipo de diente	Reducción	Código	EAN	P.V.P (€)
85	15	1,0	0,7	20	10°	ATB	Madera	B-14607	0088381362689	10,20
85	15	0,5	0,5	50	-	-	Contrachapado	792299-8	0088381101004	14,30
85	15	0,5	0,5	50	-	-	Plástico	792259-0	0088381100816	11,00

**Ø 165mm DHS660 - DHS661 - DSS610 - DHS680**

165	20	1,6	1	40	18°	ATAF	Madera	B-32954	0088381421829	27,00
165	20	1,5	1	24	20°	ATAF	Madera	B-32910	0088381421782	25,00
165	20	1,4	1	25	23	Efficut	Madera	B-62985	0088381531474	31,00
165	20	1,45	1	56	23°	Efficut	Madera	B-57336	0088381518420	55,00
165	20	1,5	1	24	15°	Efficut composite	Madera	E-12217	0088381584753	30,00
165	20	1,5	1	40	15°	Efficut composite	Madera	E-12223	0088381584760	43,00
165	20		1	24		Efficut	Madera	B-32904	0088381421713	26,00
165	20		1	40		Efficut	Madera	B-32960	0088381421836	29,00

**Ø 190mm DHS710 - DHS782 - DHS783 - HS004G**

190	30	2	1,4	24	20°	ATAF	Madera	B-32926	0088381421799	24,50
190	30	2	1,4	40	10°	ATAF	Madera	B-32976	0088381421843	33,00
190	20	1,85	1,35	50	8	Efficut composite	Madera	E-12251	0088381584784	61,00
190	30	1,5	1	24	23°	Corte limpio	-	B-64185	0088381533881	31,00

**Ø 216mm DHS900**

216	30	-	-	45	-	-		E-06971	0088381570725	48,00
216	30	2	1,5	60	8	Efficut composite	Madera	E-12267	0088381584791	71,00

**Ø 235mm DHS900 - HS009G**

235	30	2,2	1,5	24	20	Efficut	Madera	E-01909	0088381337236	44,00
-----	----	-----	-----	----	----	---------	--------	---------	---------------	-------

**Ø 260mm -**

260	30	2,15	1,65	75	8	Efficut composite	Madera	E-12273	0088381572040	80,00
-----	----	------	------	----	---	-------------------	--------	---------	---------------	-------



Discos de sierra para ingletadoras

Discos MakBlade corte silencioso



Los discos de sierra MAKBLADE PLUS tienen una tecnología única y patentada. Estos discos están desarrollados para atenuar las vibraciones y el ruido. La vida de los dientes se alarga significativamente cuidando su carburo de tungsteno mejor que

los discos convencionales.

- Menor vibración y menor ruido.

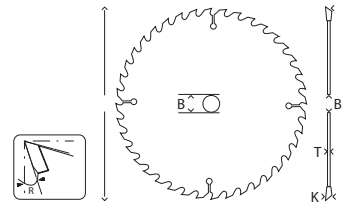

**Ø 190mm DLS600 - DLS714 - LS0714F**

Ø ext. (mm)	Ø int. (mm)	K (mm)	T (mm)	Nº dientes	R	Tipo de diente	Reducción	Código	EAN	P.V.P (€)
190	20	2.0	1,4	60	5°	ATAF	-	B-08757	0088381336741	53,50

**Ø 250mm DLS111 - LF1000 - LH1040F - LS004G - LS1018L - LS1019L - LS1040F**

250	30	2,6	1,8	80	5°	TCG	-	B-42640	0088381440882	98,00
250	30	2,6	1,8	80	5°	HI - ATB	-	B-42662	0088381440905	98,00
250	30	3,2	2,2	80	5°	TCG	-	B-42830	0088381433969	98,00
250	30	3,2	2,2	80	5°	HI - ATB	-	B-42852	0088381433983	98,00

**Ø 260mm DLS111 - LF1000 - LH1040F - LS004G - LS1018L - LS1019L - LS1040F**

260	30	2,3	1,8	70	5°	ATAF		B-32530	0088381421348	78,80
-----	----	-----	-----	----	----	------	--	---------	---------------	-------

**Ø 305mm DLS211 - LH1201FL - LS003G - LS1219L**

305	30	2,5	1,9	70	0°	ATAF		B-32568	0088381421379	92,00
-----	----	-----	-----	----	----	------	--	---------	---------------	-------



Discos MakBlade



Para un gran número de aplicaciones desde corte grueso a corte con un acabado extra fino.

- Las sierras de acero tensionado absorben los impactos sin deformarse.
- Carburo de tungsteno de alta calidad y bajo desgaste para una larga vida de la sierra.
- Corte fino con menos viruta y menos esfuerzo en el motor.

**Ø 190mm DLS600 - LS0714F - DLS714**

Ø ext. (mm)	Ø int. (mm)	K (mm)	T (mm)	Nº dientes	R	Tipo de diente	Reducción	Código	EAN	P.V.P (€)
190	20	2,2	1,6	24	5°	ATB	-	B-32708	0088381421515	26,00
190	20	2.0	1,4	60	5°	ATB	-	B-09042	0088381337083	39,00

**Ø 216mm LS002G - LS0815FL**

216	30	2,1	1,6	40	10°	ATB	-	A-86169	0088381150026	49,50
216	30	2,4	1,6	48	5°	ATB	-	B-32764	0088381421577	50,50
216	30	2,2	1,6	80	5°	ATB	-	A-86468	0088381150804	74,00

**Ø 260mm DLS111 - LF1000 - LH1040F - LS004G - LS1018L - LS1019L - LS1040F**

255	30	2,3	1,8	32	5°	ATB	-	B-32720	0088381421539	62,50
255	30	2,3	1,8	60	5°	ATB	-	B-32792	0088381421607	48,80
260	30	2,3	1,8	40	5°	ATB	-	B-32770	0088381421584	40,00
260	30	2,3	1,8	60	5°	ATB	-	B-32801	0088381421614	48,00
260	30	2,3	1,8	80	5°	ATB	-	B-32845	0088381421652	52,50
260	30	2,3	1,8	100	5°	ATB	-	B-32873	0088381421683	58,50
260	30	2,5	1,65	80	10°	Efficut	-	B-67240	0088381541015	70,00

**Ø 305mm LH1201FL - LS1219L - DLS211**

305	30	2,3	1,8	40	5°	ATB	-	B-32786	0088381421591	51,50
305	30	2,3	1,8	60	5°	ATB	-	B-32817	0088381421621	67,00
305	30	2,3	1,8	80	5°	ATB	-	B-32851	0088381421669	80,00
305	30	2,3	1,8	100	5°	ATB	-	B-32889	0088381421690	88,00
305	30	2,15	1,65	60	10°	Efficut	-	B-67309	0088381541022	83,00





**Discos de sierra para ingletadoras**

**Discos Specialized Aluminio**



- Chapa de precisión tensionada para mayor rigidez y cortes más rectos.
- Excelente calidad de corte en materiales no ferrosos.
- Perfecta realización del corte en suelos laminados.

Aplicar cera de discos en la zona del diente frecuentemente para prevenir la acumulación de viruta en los dientes cuando cortemos metales no ferrosos.

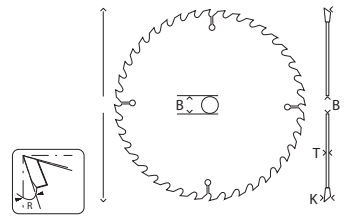

**Ø 190mm DLS600 - DLS714Z - LS0714F**

Ø ext. (mm)	Ø int. (mm)	K (mm)	T (mm)	N° dientes	R	Tipo de diente	Reducción	Código	EAN	P.V.P (€)
190	20	2	1,4	60	-5°	TCG	-	B-33283	0088381422154	51,00

**Ø 216mm LS0815FL - LS002G**

216	30	2,2	1,6	64	-5°	TCG	-	B-33299	0088381422178	57,50
-----	----	-----	-----	----	-----	-----	---	---------	---------------	-------

**Ø 260mm DLS111 - LF1000 - LH1040F - LS004G - LS1018L - LS1019L - LS1040F**

250	30	2,4	1,8	72	5	ATB	-	B-33308	0088381422185	61,50
250	30	2,4	1,8	100	-5°	TCG	-	B-33314	0088381422192	73,00
260	30	2,4	1,8	80	-5°	TCG	-	B-33320	0088381422208	67,00
260	30	2,4	1,8	100	-5°	TCG	-	B-33336	0088381422215	75,00
260	30	1,85	1,5	81	-3°	SMTCG	-	E-06317	0088381568968	87,00

**Ø 305mm DLS211 - LH1201FL - LS003G - LS1219L**

305	30	2,4	1,8	80	-5°	TCG	-	B-33342	0088381422222	83,00
305	30	2,4	1,8	100	-5°	TCG	-	B-33358	0088381422239	98,00
305	30	2	1,65	81	-3	Efficut	-	E-13253	0088381591270	123,00
305	30	2	1,65	96	-3	Efficut	-	E-13312	0088381591287	138,00



★★★★  
★★★★

**Discos Specialized Standard Economy**



Ø ext. (mm)	Ø int. (mm)	K (mm)	T (mm)	N° dientes	R	Tipo de diente	Reducción	Código	EAN	P.V.P (€)
216	30	2,2	1,5	40	15°	TCT	-	D-77344	0088381718134	16,00
255	30	2,6	1,8	40	15°	ATB	-	D-74049	0088381587082	18,70
305	30	2,8	2	60	15°	ATB	-	D-72316	0088381569040	35,00
305	30	2,8	2	80	15°	ATB	-	D-72322	0088381569057	40,00
305	30	2,8	2	100	15°	ATB	-	D-72338	0088381569064	45,00



**Discos Specialized Sierras de mesa - Madera**



- Diseñados para sierras de mesa Makita y otros fabricantes de sierras.

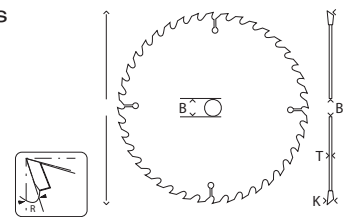

<b>Ø 260mm 2704 y MLT100</b>										
260	30	2,3	1,5	40	20°	TCG	-	B-05072	0088381200677	46,00
260	30	2,6	1,8	40	15°	ATB	-	D-74077	0088381587112	19,30
<b>Ø 315mm 2712</b>										
315	30	2,8	2,0	40	16°	Corte rápido	-	JM27170001	0088381531641	33,00

**Discos Specialized Sierras de mesa - Aluminio**



<b>Ø 260mm 2704 - MLT100</b>										
Ø ext. (mm)	Ø int. (mm)	K (mm)	T (mm)	Nº dientes	R	Tipo de diente	Reducción	Código	EAN	P.V.P (€)
260	30	2,8	2,2	80	0°	TCG	-	B-33386	0088381422260	83,00
<b>Ø 300mm</b>										
300	30	2,8	2,2	80	0°	TCG	-	B-33392	0088381422277	94,50

**Discos Specialized laminados**



- Excelente calidad de corte en suelos laminados.
- Gran precisión de corte en molduras y rodapiés.

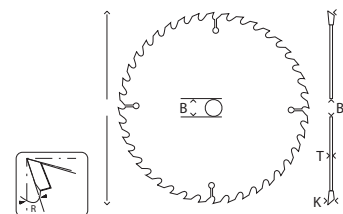

<b>Ø 216mm LS0815FL - LS002G</b>										
Ø ext. (mm)	Ø int. (mm)	K (mm)	T (mm)	Nº dientes	R	Tipo de diente	Reducción	Código	EAN	P.V.P (€)
216	30	2,5	1,8	72	5°	TCG	-	B-33853	0088381422703	110,00
<b>Ø 260mm DLS111 - LF1000 - LH1040F - LS004G - LS1018L - LS1019L - LS1040F</b>										
260	30	2,5	1,8	84	5°	TCG	-	B-33875	88381422727	134,00
<b>Ø 305mm DLS211 - LH1201FL - LS003G - LS1219L</b>										
305	30	2,5	1,8	96	5°	TCG	-	B-33881	0088381422734	168,00

**Disco PCD especial fibrocemento**



<b>Ø 165mm</b>										
Ø ext. (mm)	Ø int. (mm)	K (mm)	T (mm)	Nº dientes	R	Tipo de diente	Reducción	Código	EAN	P.V.P (€)
165	20	1,8	1,4	4	12°	PCD	-	D-72067	0088381568227	36,00

Mesa para ingletadoras



194043-3



DEAWST05



DEAWST06  
DEAWST07



Largo (mm)	Alto (mm)	Ancho (mm)	Modelos	Uds.	Código	EAN	P.V.P (€)
762	841	743	LS0714F LH1040F LS1019L LS1018L LS1040F LS1219L LH1201FL	1	198688-9	0088381488938	200,00
2.700	500	800	Todos los modelos	1	DEAWST05	0088381424318	349,00
2.550	750	850		1	DEBWS06	0088381567350	318,00
3.830	860	750	Válida para todos los modelos a excepción de DLS600, LH1040/F y LH1201FL.	1	DEAWST07	0088381565301	435,00





## Sierras de sable

### Tipos de dientes

#### Diente triscado fresado

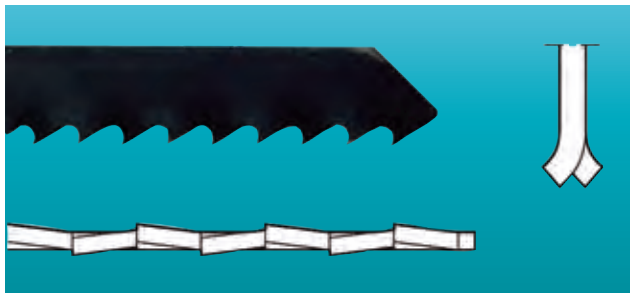

#### Diente triscado prensado

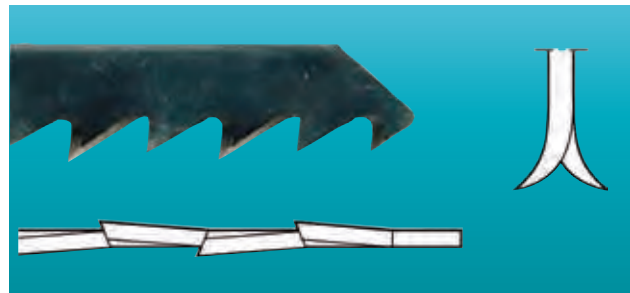

#### Diente ondulado fresado

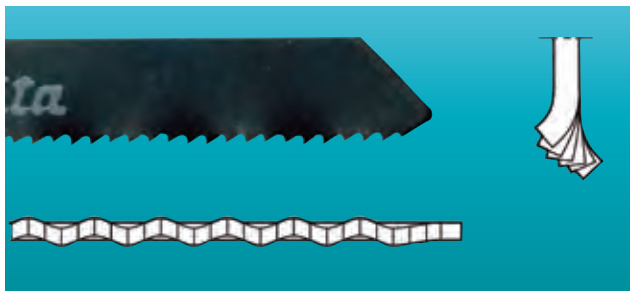

#### Diente recto prensado

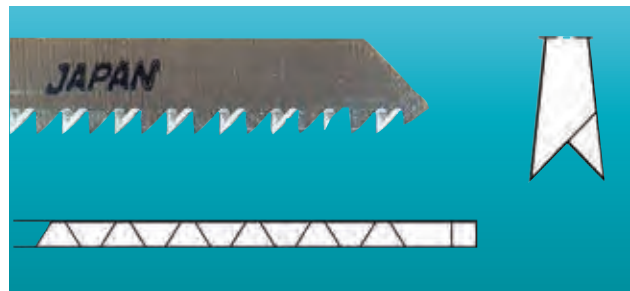

### Fabricación de los dientes

#### Dientes fresados

- Coste reducido de fabricación
- Para realizar cortes generales menos precisos
- Para cortar materiales blandos y duros
- Uso útil de la hoja prolongado



#### Dientes prensados

- Coste de fabricación mayor
- Mayor afilado
- Para cortes más precisos
- Para cortar materiales blandos y medios



### Método de fabricación

**Triscado:** Cada diente se dobla hacia la derecha o hacia la izquierda manualmente, dejando uno centrado después. Ej: Izquierda, derecha, centrado, etc.

**Ondulado:** La hilera entera de dientes se moldea para tener una forma curva y ondulada.

**Recto:** La hilera de dientes se hace más estrecha obteniendo una forma cónica.



### Material de las sierras

**HCS (Acero de alto carbono):** Para cortar materiales más blandos como maderas o plásticos.

**HSS (Acero de alta velocidad):** Para cortar materiales más duros como metales.

**BiM (Bi-Metal, Base HCS y dientes HSS):** Al combinar ambos tipos de aceros, podemos cortar materiales blandos y duros.

**TC (Carburo de tungsteno):** Para cortar plásticos reforzados con fibra de vidrio, tableros de fibra aglomerada con cemento o cartón-yeso.



Tipo de dentado

Tipo A

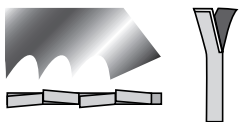

• Dentado: afilado triscado, cortes rápidos en maderas duras y blandas, aluminio, plásticos y metales no ferrosos.

Tipo B

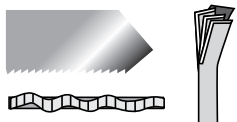

• Dentado: afilado ondulado, corte fino y limpio en madera, acero blando, aluminio y metales no ferrosos.

Tipo C

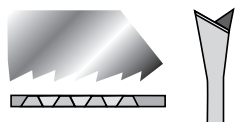

• Dentado: afilado trapezoidal, cortes finos y limpios en madera y plásticos.

Tipo D

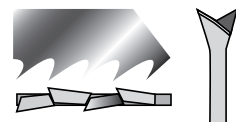

• Dentado: afilado triscado trapezoidal, cortes gruesos y rápidos en madera.

Sierras de sable

Metal



N  
N  
N  
N  
N  
N

Características	Tipo	Tipo de dientes	Dientes / pulgada	Largo (mm)	Ancho (mm)	Uds.	Código	EAN	P.V.P. (€)
Para corte en metal de 3 a 8 mm.	BiM	B	14	225	0,9	2	D-51655	0088381442978	8,50
Para corte en metal de 1,5 a 2,5 mm			18	225	0,9	2	D-51661	0088381442985	7,25
Para corte en metal menor de 1,2 mm			24	225	0,9	2	D-51677	0088381442992	7,50
Para corte en metal de 3 a 8 mm.			14	150	0,9	2	D-51627	0088381442947	6,50
Para corte en metal de 1,5 a 2,5 mm			18	150	0,9	2	D-51633	0088381442954	5,50
Para corte en metal menor de 1,2 mm			24	152	0,9	2	D-51649	0088381442961	5,50



N  
N  
N  
N  
N  
N  
N

Características	Tipo	Tipo de dientes	Dientes / pulgada	Largo (mm)	Ancho (mm)	Uds.	Código	EAN	P.V.P. (€)
Para corte en metal de 3 a 8 mm.	BiM	B	14	225	0,9	25	D-51655-25	0088381470582	69,00
Para corte en metal de 1,5 a 2,5 mm			18	225	0,9	25	D-51661-25	0088381470599	69,00
Para corte en metal menor de 1,2 mm			24	225	0,9	25	D-51677-25	0088381470605	69,00
Para corte en metal de 3 a 8 mm.			14	150	0,9	25	D-51627-25	0088381470551	50,00
Para corte en metal de 1,5 a 2,5 mm			18	150	0,9	25	D-51633-25	0088381470568	50,00
Para corte en metal menor de 1,2 mm			24	150	0,9	25	D-51649-25	0088381470575	50,00
Para corte de chapa mayor a 1,2 mm			24	152	0,9	25	B-16835-25	0088381485890	56,00



Características	Tipo	Tipo de dientes	Dientes / pulgada	Largo (mm)	Ancho (mm)	Uds.	Código	EAN	P.V.P. (€)
Para corte de acero, inoxidable y metales no ferrosos entre 3,5mm y 5mm. (El color de la hoja puede variar - azul o blanca).	BiM	B	10 / 14	305	0,9	5	B-16857	0088381367554	22,00
				225			P-47008	0088381977432	21,00
				152			P-46997	0088381977425	16,10



Características	Tipo	Tipo de dientes	Dientes / pulgada	Largo (mm)	Ancho (mm)	Uds.	Código	EAN	P.V.P. (€)
Para corte de metal de 4mm a 12mm. Corte rápido.	BiM	B	8 / 10	305	0,9	5	B-43212	0088381443081	26,00
				225			B-43181	0088381443050	22,00
				152			B-43147	0088381443012	18,50

**Metal**



Características	Tipo	Tipo de dientes	Dientes / pulgada	Largo (mm)	Ancho (mm)	Uds.	Código	EAN	P.V.P. (€)
Diente en M para el corte rápido de acero, inoxidable y metales no ferrosos. Corta en las dos direcciones para aumentar la velocidad de corte.	BiM	M	M	260	0,9	5	P-45727	0088381976169	27,00
				200			P-45711	0088381976152	22,00
				150			P-45705	0088381976145	18,30



Características	Tipo	Tipo de dientes	Dientes / pulgada	Largo (mm)	Ancho (mm)	Uds.	Código	EAN	P.V.P. (€)
Chapa gruesa. 4-12mm, tubo <100mm.	TC	-	8	152	1,25	1	B-55572	0088381483575	18,70
Chapa gruesa. 4-12 mm, tubo <175 mm.	TC	-	8	228	1,25	1	B-55588	0088381483582	22,00
Chapa gruesa. 4-12 mm, tubo <250 mm.	TC	-	8	305	1,25	1	B-55594	0088381483599	29,00



Características	Tipo	Tipo de dientes	Dientes / pulgada	Largo (mm)	Ancho (mm)	Uds.	Código	EAN	P.V.P. (€)
Para corte de chapa menor a 1,2mm.	BiM	B	32	150	0,9	5	P-04955	0088381914109	16,60

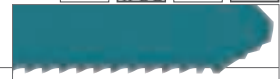

Características	Tipo	Tipo de dientes	Dientes / pulgada	Largo (mm)	Ancho (mm)	Uds.	Código	EAN	P.V.P. (€)
Para corte de chapa mayor a 1,2mm. (El color de la hoja puede variar - azul o blanca).	BiM	B	24	225	0,9	5	B-43169	0088381443036	18,70
				152			B-16835	0088381367530	12,70
				152		B-16835-2	0088381559775	5,50	
				100		P-04896	0088381914048	14,90	



Características	Tipo	Tipo de dientes	Dientes / pulgada	Largo (mm)	Ancho (mm)	Uds.	Código	EAN	P.V.P. (€)
Para corte de acero e inoxidable entre 1,5mm y 2,5mm (El color de la hoja puede variar - azul o blanca).	BiM	B	12	225	0,9	5	B-16776	0088381367479	17,70
				152			B-05169	0088381204224	13,80
				100			P-04874	0088381914024	14,90



Características	Tipo	Tipo de dientes	Dientes / pulgada	Largo (mm)	Ancho (mm)	Uds.	Código	EAN	P.V.P. (€)
Para corte de metal de 3mm a 8mm.	BiM	B	14 / 18	305	1,1	5	B-43206	0088381443074	26,00
				225			B-43175	0088381443043	22,00
				152			B-43131	0088381443005	17,70



**Metal**



Características	Tipo	Tipo de dientes	Dientes / pulgada	Largo (mm)	Ancho (mm)	Uds.	Código	EAN	P.V.P. (€)
Para corte de acero e inoxidable entre 1,5mm y 2,5mm.	BiM	B	18	225	0,9	5	B-16782	0088381367486	17,70
				152			B-16841	0088381367547	12,70



Características	Tipo	Tipo de dientes	Dientes / pulgada	Largo (mm)	Ancho (mm)	Uds.	Código	EAN	P.V.P. (€)
Para corte de metal de 2mm a 10mm. Corte fino.	BiM	B	10 / 14	305	1,25	5	B-43228	0088381443098	26,00
				225			B-43197	0088381443067	22,00
				152			B-43153	0088381443029	17,70

**Sets de sierras de sable para metal y madera**



P-81290 - Metal

P-81278 - Madera



- Juego de hojas de sierra para cortar metal o madera con estuche de plástico. Con tres tipos de dientes diferentes, para chapa fina, media y gruesa.

Tipo	Dientes / pulgada	Largo (mm)	Uds.	Código	EAN	P.V.P. (€)
HCS	4	150	27	P-81278	0088381470582	57,00
BiM	14 / 18 / 24	150	30	P-81290	0088381470599	87,00



**Madera**



Características	Tipo	Tipo de dientes	Dientes / pulgada	Largo (mm)	Ancho (mm)	Uds.	Código	EAN	P.V.P. (€)
Para toda clase de maderas con un acabado fino.	HCS / CV	A	10	152	1,05	5	B-16807	0088381367509	9,60

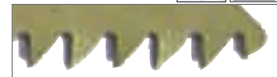

Características	Tipo	Tipo de dientes	Dientes / pulgada	Largo (mm)	Ancho (mm)	Uds.	Código	EAN	P.V.P. (€)
Hoja gruesa para cortes rápidos en madera, plásticos y placas de yeso.	HCS / CV	A	6	305	1,25	5	B-16829	0088381367523	16,00



Características	Tipo	Tipo de dientes	Dientes / pulgada	Largo (mm)	Ancho (mm)	Uds.	Código	EAN	P.V.P. (€)
Hoja gruesa para cortes rápidos en madera, plásticos y placas de yeso.	HCS / CV	A	6	225	1,27	5	P-47092	0088381977524	14,90



Características	Tipo	Tipo de dientes	Dientes / pulgada	Largo (mm)	Ancho (mm)	Uds.	Código	EAN	P.V.P. (€)
Hoja gruesa para cortes rápidos en madera, plásticos y placas de yeso.	HCS / CV	C	6	150	1,27	5	P-47086	0088381977517	13,70



Características	Tipo	Tipo de dientes	Dientes / pulgada	Largo (mm)	Ancho (mm)	Uds.	Código	EAN	P.V.P. (€)
Hoja gruesa para cortes rápidos en madera, plásticos y placas de yeso.	BIM	A	6	150	1,27	5	P-05088	0088381914314	22,00



Características	Tipo	Tipo de dientes	Dientes / pulgada	Largo (mm)	Ancho (mm)	Uds.	Código	EAN	P.V.P. (€)
Hoja especial para madera verde	HCS/CV	C	5	305	1,5	5	B-16863	0088381367561	20,00



Características	Tipo	Tipo de dientes	Dientes / pulgada	Largo (mm)	Ancho (mm)	Uds.	Código	EAN	P.V.P. (€)
Hoja especial para madera verde	HCS/CV	C	4 - 5	240	1,27	5	P-47117	0088381977548	16,60

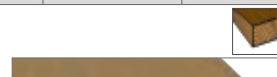

Características	Tipo	Tipo de dientes	Dientes / pulgada	Largo (mm)	Ancho (mm)	Uds.	Código	EAN	P.V.P. (€)
Para corte curvo en madera y plástico.	HCS/CV	C	6	152	1,27	5	B-16798	0088381367493	9,60
						2	B-53089	0088381445771	4,00

N

**Madera**

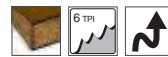

Características	Tipo	Tipo de dientes	Dientes / pulgada	Largo (mm)	Ancho (mm)	Uds.	Código	EAN	P.V.P. (€)
Para corte curvo y limpio en madera, plástico y plexiglás.	HCS / CV	D	6	150	1,8	5	P-47101	0088381977531	21,00

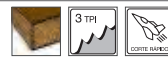

Características	Tipo	Tipo de dientes	Dientes / pulgada	Largo (mm)	Ancho (mm)	Uds.	Código	EAN	P.V.P. (€)
Hoja gruesa para cortes rápidos en madera, plásticos y placas de yeso.	HCS / CV	A	3	152	1,25	5	B-16813	0088381367516	9,60



Características	Tipo	Tipo de dientes	Dientes / pulgada	Largo (mm)	Ancho (mm)	Uds.	Código	EAN	P.V.P. (€)
Dentado muy grueso para cortes rápidos y agresivos en maderas húmedas.	HCS / CV	C	3	240	1,27	5	P-47123	0088381977555	17,80



Características	Tipo	Tipo de dientes	Dientes / pulgada	Largo (mm)	Ancho (mm)	Uds.	Código	EAN	P.V.P. (€)
Dentado muy grueso para cortes rápidos y agresivos en maderas húmedas.	HCS / CV	D	8,5	250	1,0	1	B-62016	0088381528719	16,50

**S-EXPRESS**



Características	Tipo	Tipo de dientes	Dientes / pulgada	Largo (mm)	Ancho (mm)	Uds.	Código	EAN	P.V.P. (€)
Hoja superexpress con un gran rendimiento en las sierras de sable a batería: Metal.	BiM	-	7 - 18	152	-	5	B-05038	0088381200592	17,70

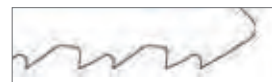

Características	Tipo	Tipo de dientes	Dientes / pulgada	Largo (mm)	Ancho (mm)	Uds.	Código	EAN	P.V.P. (€)
Hoja superexpress con un gran rendimiento en las sierras de sable a batería: Universal.	BiM	-	6 - 11	152	-	5	B-05044	0088381200608	15,40



Características	Tipo	Tipo de dientes	Dientes / pulgada	Largo (mm)	Ancho (mm)	Uds.	Código	EAN	P.V.P. (€)
Hoja superexpress con un gran rendimiento en las sierras de sable a batería: Madera.	BiM	-	6 - 10	203	-	5	B-05153	0088381200943	16,00



**Madera + Metal**

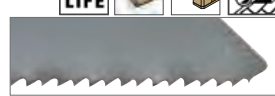

Características	Tipo	Tipo de dientes	Dientes / pulgada	Largo (mm)	Ancho (mm)	Uds.	Código	EAN	P.V.P. (€)
Especial Palet	BIM	B	10	180	0,9	200	B-54265	0088381477307	455,00



Características	Tipo	Tipo de dientes	Dientes / pulgada	Largo (mm)	Ancho (mm)	Uds.	Código	EAN	P.V.P. (€)
Especial para la reparación de palets. Para corte de madera con residuos metálicos. Hoja gruesa.	BIM	A	8/10	150	1,27	5	P-47064	0088381977494	20,00



Características	Tipo	Tipo de dientes	Dientes / pulgada	Largo (mm)	Ancho (mm)	Uds.	Código	EAN	P.V.P. (€)
Madera con clavo, pvc, demolición.	BIM	-	5/8	305	1,6	5	B-43278	0088381443142	32,00
	BIM	-	5/8	225	1,6	5	B-43256	0088381443128	28,00
	BIM	-	5/8	152	1,6	5	B-43234	0088381443104	22,00



Características	Tipo	Tipo de dientes	Dientes / pulgada	Largo (mm)	Ancho (mm)	Uds.	Código	EAN	P.V.P. (€)
Diente en M para el corte rápido de madera y madera con clavo. Corta en las dos direcciones para aumentar la velocidad de corte.	BIM	A	6	152	1,25	5	B-05175	0088381204231	16,00



Características	Tipo	Tipo de dientes	Dientes / pulgada	Largo (mm)	Ancho (mm)	Uds.	Código	EAN	P.V.P. (€)
Diente en M para el corte rápido de madera y madera con clavo. Corta en las dos direcciones para aumentar la velocidad de corte.	BIM	M	-	200	0,9	5	P-45696	0088381976138	22,00
	BIM	M	-	150	0,9	5	P-45680	0088381976121	18,30



**Madera + Metal**



Características	Tipo	Tipo de dientes	Dientes / pulgada	Largo (mm)	Ancho (mm)	Uds.	Código	EAN	P.V.P. (€)
Especial para la reparación de palets. Para corte de madera con residuos metálicos. Hoja gruesa.	BiM	A	10 / 14	225	1,27	5	P-47195	0088381977623	21,00
	BiM	A	10 / 14	150	1,27	5	P-47189	0088381977616	16,10



Características	Tipo	Tipo de dientes	Dientes / pulgada	Largo (mm)	Ancho (mm)	Uds.	Código	EAN	P.V.P. (€)
Especial para la reparación de palets. Para corte de madera con residuos metálicos. Hoja fina.	BiM	A	10 / 14	280	0,9	5	P-67767	0088381998291	26,00
	BiM	A	10 / 14	152	0,9	5	P-47014	0088381977449	15,40



Características	Tipo	Tipo de dientes	Dientes / pulgada	Largo (mm)	Ancho (mm)	Uds.	Código	EAN	P.V.P. (€)
Especial palet. Madera con clavo, PVC y aluminio.	BiM	B	10 / 14	225	0,9	5	B-43262	0088381443135	18,70
	BiM	B	10 / 14	152	0,9	5	B-43240	0088381443111	13,80

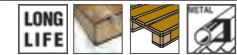

Características	Tipo	Tipo de dientes	Dientes / pulgada	Largo (mm)	Ancho (mm)	Uds.	Código	EAN	P.V.P. (€)
Especial palet, madera con clavo, aluminio.	BiM	B	10	225	0,9	5	B-31859	0088381420129	18,70
	BiM	B	10	152	0,9	5	B-31843	0088381420112	13,80



**ESPECIALES - Rescate - Multimaterial**



Características	Tipo	Tipo de dientes	Dientes / pulgada	Largo (mm)	Ancho (mm)	Uds.	Código	EAN	P.V.P. (€)
Sierra de sable de rescate 152x1,25 mm 6-8 TPI. Recomendada para situaciones de rescate.	TC / HM	-	6 - 8	152	1,25	25	B-67206	0088381540759	312,00
Sierra de sable de rescate 225/1,25x6-8 TPI	TC / HM	-	6 - 8	225	1,25	25	B-67212	0088381540766	495,00

ESPECIALES



Características	Tipo	Tipo de dientes	Dientes / pulgada	Largo (mm)	Ancho (mm)	Uds.	Código	EAN	P.V.P. (€)
Ideal para maderas duras, hormigón esponjoso, eternita y plásticos reforzados con fibra de vidrio y epoxy. Dientes de carburo de tungsteno	HM	A	3	400	1,3	1	P-05066	0088381914215	49,00
	HM	A	6	300	1,3	-	P-05050	0088381914208	55,00
				150			P-05044	0088381914192	26,00
				100			P-05038	0088381914185	22,00



Características	Tipo	Tipo de dientes	Dientes / pulgada	Largo (mm)	Ancho (mm)	Uds.	Código	EAN	P.V.P. (€)
Especial para ladrillo.	HM	-	2	400	-	1	B-10403	0088381342667	50,00
				265			B-10394	0088381342650	36,00



Características	Tipo	Tipo de dientes	Dientes / pulgada	Largo (mm)	Ancho (mm)	Uds.	Código	EAN	P.V.P. (€)
Especial para ladrillo hueco.	HM - TC	-	2	240	-	1	B-12809	0088381355544	28,00



Características	Tipo	Tipo de dientes	Dientes / pulgada	Largo (mm)	Ancho (mm)	Uds.	Código	EAN	P.V.P. (€)
Para cortes en cerámica, hierro de fundición, ladrillo muy duro y plásticos reforzados con fibra de vidrio y epoxy.	CV-HM	-	-	180	1,05	2	P-47173	0088381977609	17,20



Características	Tipo	Tipo de dientes	Dientes / pulgada	Largo (mm)	Ancho (mm)	Uds.	Código	EAN	P.V.P. (€)
Especial para productos congelados. Hoja de acero inoxidable sin pinturas.	INOX	-	6	152	-	1	B-52043	0088381467544	24,00
		A		305			B-10609	0088381346641	10,20
		-		228			B-30564	0088381418607	24,00



Características	Tipo	Tipo de dientes	Dientes / pulgada	Largo (mm)	Ancho (mm)	Uds.	Código	EAN	P.V.P. (€)
Especial para corte en inoxidable.	HN	-	18	152	-	2	B-07250	0088381310734	32,00



Características	Tipo	Tipo de dientes	Dientes / pulgada	Largo (mm)	Ancho (mm)	Uds.	Código	EAN	P.V.P. (€)
Fibrocemento / Ladrillo 10-250mm epoxy 6-150mm	TC / HM	-	3	305	1,5	2	B-63585	0088381532846	43,00



Características	Tipo	Tipo de dientes	Dientes / pulgada	Largo (mm)	Ancho (mm)	Uds.	Código	EAN	P.V.P. (€)
Fibrocemento / Ladrillo 20-350mm epoxy 6-150mm	TC / HM	-	2	400	1,5	2	B-63591	0088381532853	51,00















Explicación de símbolos y materiales

**Materiales**

	Madera		Corte imperfecto
	Madera con clavos		Corte perfecto
	Aglomerado		Aluminio
	Parquet laminado		Acero Inoxidable
	Plástico reforzado con fibra de vidrio		Placas Sandwich
	PVC (plástico)		Cristal, cerámica
	Metal		Goma, cuero, material aislante

**Tipo de hoja**

		Calidad del material de la sierra		Larga vida
				Cuchilla extremadamente afilada
	Corte recto		CORTE RÁPIDO	Corte rápido
	Corte curvo		DUD	Cuchilla doble
	Dentado con los dientes inclinados		COMBO	Combinado



**Corte Super Express**



Tipo	Descripción	Dientes por pulgada	Longitud útil (mm)	Calidades material	Madera	Plástico	Aluminio	Metal inox	Metal no ferroso	Metal	Tipo Clase B	Uds. paquete	Código	EAN	P.V.P (€)
B-50	Hoja superexpress con un gran rendimiento en las caladoras a batería: madera y plásticos.	8 - 11	73	HCS	5,5	5,5	-	-	-	-	T234X	5	B-06460	0088381276702	8,60



B-51	Hoja superexpress con un gran rendimiento en las caladoras a batería: Metal	10 - 18	73	HHS	-	-	-	1,3	-	1,8	T123X	5	B-06476	0088381276719	8,60
------	---	---------	----	-----	---	---	---	-----	---	-----	-------	---	---------	---------------	------



B-52	Hoja superexpress con un gran rendimiento en las caladoras a batería: Universal	6 - 10	73	HHS	5,5	5,5	-	-	-	-	T345XF	5	B-06482	0088381276726	10,20
------	---	--------	----	-----	-----	-----	---	---	---	---	--------	---	---------	---------------	-------



-	Conjunto Super Express	-	77	HHS	-	-	-	-	-	-	-	3	B-06292	0088381249713	6,80
---	------------------------	---	----	-----	---	---	---	---	---	---	---	---	---------	---------------	------

**Corte básico - Madera**



B13	Para cortes en madera y plásticos	8	75	HCS	4-65	4-65	-	-	-	-	T111C	2	B-01286	0088381117395	2,50
												5	A-85656	0088381149563	4,50



B15	Para madera prensada y tableros de fibra de hasta 3mm, plásticos hasta 35mm.	12	50	HCS	3-35	3-35	-	-	-	-	T119B	5	A-85678	0088381149655	4,20
-----	--	----	----	-----	------	------	---	---	---	---	-------	---	---------	---------------	------



B14	Para madera prensada y tableros de fibra de hasta 8mm, plásticos hasta 35mm (corte rápido).	18	51	HCS	2-35	2-35	-	-	-	-	-	5	A-85662	0088381149648	4,20
-----	---	----	----	-----	------	------	---	---	---	---	---	---	---------	---------------	------



B18	Ideal para cortes en curva en madera y plástico	14	44	HCS	2-35	2-35	-	-	-	-	T119BO	5	A-85709	0088381149662	4,80
-----	---	----	----	-----	------	------	---	---	---	---	--------	---	---------	---------------	------

N













































**Corte rápido - Madera**



Tipo	Descripción	Dientes por pulgada	Longitud útil (mm)	Calidades material	Madera	Plástico	Aluminio	Metal inox	Metal no ferroso	Metal	Tipo Clase B	Uds. paquete	Código	EAN	P.V.P (€)
        															
B16	Para corte rápido en madera y plástico. Corte rápido y basto.	6	75	HCS	5-65	5-65	-	-	-	-	T144D	2	B-01292	008838117401	2,75
												5	A-85684	0088381149686	6,00
        															
L02	Ideal para cortes rápidos en materiales gruesos	6	100	HCS	5-90	5-90	-	-	-	-	-	5	A-86309	0088381150279	8,60
        															
L10	Para todo tipo de cortes en madera. Corte rápido y basto.	6	151	HCS	5-135	5-135	-	-	-	-	T344D	5	A-86315	0088381150286	11,80
        															
B17	Ideal para cortes en curva en madera y plásticos. (corte rápido).	6	70	HCS	5-60	-	-	-	-	-	T244D	2	B-01301	008838117418	3,25
												5	A-85690	0088381149693	6,20
        															
-	Corte curvo y rápido para toda clase de maderas.	6	75	HCS/CV	8-65	-	-	-	-	-	-	5	P-31572	0088381959735	8,30
      															
-	Corte rápido en toda clase de maderas con una prolongada vida útil.	6	75	BIM	8-65	-	-	-	-	-	T144DF	5	P-31588	0088381959742	10,90
      															
B37	Corte rápido y curvo	9	105	HCS	8-65	-	-	-	-	-	-	5	E-22218	008838171786	24,00































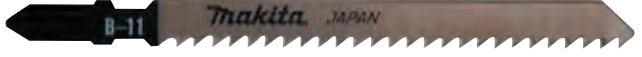



















































**Corte maderas laminadas**





























Tipo	Descripción	Dientes por pulgada	Longitud útil (mm)	Calidades material	Madera	Plástico	Aluminio	Metal inox	Metal no ferroso	Metal	Tipo Clase B	Uds. paquete	Código	EAN	P.V.P (€)
        															
B19	Para madera laminada y chapa decorativa de acabado. Dientes invertidos.	12	63	HCS	3-50	3-50	-	-	-	-	T101BR	5	A-85715	0088381149709	5,90
        															
B28	Para madera laminada y chapa decorativa de acabado.	16	63	HSS	2-50	2-50	-	-	-	-	T101BIF	5	A-80391	0088381136938	11,20
         															
B-53	Para corte recto en laminados, suelos de madera y maderas decorativas. Sin astillas.	15	82	-	-	-	-	-	-	-	T101BIF	5	B-10970	0088381351461	13,60
         															
B-54	Para corte curvo en laminados, suelos de madera y maderas decorativas. Sin astillas.	15	82	-	-	-	-	-	-	-	T101AOF	5	B-10986	0088381351478	15,90
      															
B16	Hoja especial para cortes en superficie sin astillas, en laminado y parquet	12	60	BIM	5-20	-	-	-	-	-	T101AIF	5	P-31566	0088381959728	11,20



**Corte limpio madera**

Tipo	Descripción	Dientes por pulgada	Longitud útil (mm)	Calidades material	Madera	Plástico	Aluminio	Metal inox	Metal no ferroso	Metal	Tipo Clase B	Uds. paquete	Código	EAN	P.V.P (€)
          															
N59	Corte rápido y limpio en toda clase de madera y plástico..	8	75	HCS	4-65	4-65	-	-	-	-	T101B	5	A-86583	0088381150934	7,80
          															
B10	Corte rápido y limpio en madera y plásticos, especialmente indicado para madera contrachapada.	9	75	HCS	3-65	3-65	-	-	-	-	-	5	A-85628	0088381149716	6,60
												2	B-01270	0088381117388	3,50
          															
B11	Para terminación de trabajos rápido. Corte limpio.	9	75	HCS	3-60	3-60	-	-	-	-	T101B	5	A-85634	0088381149549	7,00
          															
B12	Para terminación de trabajos rápido. Corte limpio.	6	75	HCS	5-65	5-65	-	-	-	-	T101D	5	A-85640	0088381149556	5,60
          															
L01	Hoja gruesa y larga para cortes limpios y rectos.	6	100	HCS	5-90	5-90	-	-	-	-	T301CD	5	A-86290	0088381150262	12,40
          															
B29	Ideal para corte curvo para madera y plásticos. (acabado).	16	42	HCS	2-35	2-35	-	-	-	-	T101AO	5	A-80400	0088381136945	10,60
          															
BR13	Corte sin astillas en madera, no requieren lijado. La hoja corta hacia arriba y abajo para un buen acabado de la superficie.	9	64	HCS	5-65	-	-	-	-	-	-	5	A-85793	0088381149679	4,80
           															
-	Corte limpio en toda clase de madera y plástico con una prolongada vida útil.	10	75	BIM	5-65	5-65	-	-	-	-	T101BF	5	P-31594	00883811959759	11,40

**Corte - Maderas duras**

Tipo	Descripción	Dientes por pulgada	Longitud útil (mm)	Calidades material	Madera	Plástico	Aluminio	Metal inox	Metal no ferroso	Metal	Tipo Clase B	Uds. paquete	Código	EAN	P.V.P (€)
             															
B25	Para madera dura, para chapa y placas metálicas gruesas	9	75	HSS	3-60	3-60	3-6	-	-	3-6	T127D	5	A-85765	0088381149600	5,60
												2	B-01345	0088381117456	3,75
           															
B26	Para cortes curvos en madera dura, metal, metal no ferroso y plásticos duros.	9	70	HSS	3-60	3-60	3-10	-	3-10	3-10	T227D	5	A-85771	0088381149617	6,30

**Corte - Madera con clavo**



Tipo	Descripción	Dientes por pulgada	Longitud útil (mm)	Calidades material	Madera	Plástico	Aluminio	Metal inox	Metal no ferroso	Metal	Tipo Clase B	Uds. paquete	Código	EAN	P.V.P (€)
M-Force	Diente en M para el corte rápido de madera, metales y madera con clavo. Corta en ambas direcciones.	5	130	BIM	105	-	-	-	-	-	-	2	P-45749	0088381976183	8,60



-	Ideal para madera con clavo.	9-10	105	BIM	5-95	-	-	-	-	2,5-10	-	5	P-49638	0088381980081	12,60
---	------------------------------	------	-----	-----	------	---	---	---	---	--------	---	---	---------	---------------	-------



-	Ideal para madera con clavo.	9-10	75	BIM	5-65	-	-	-	-	2,5-10	T111HF	5	P-49622	0088381980074	11,20
---	------------------------------	------	----	-----	------	---	---	---	---	--------	--------	---	---------	---------------	-------

**Corte básico - Metal**



Tipo	Descripción	Dientes por pulgada	Longitud útil (mm)	Calidades material	Madera	Plástico	Aluminio	Metal inox	Metal no ferroso	Metal	Tipo Clase B	Uds. paquete	Código	EAN	P.V.P (€)
N51	Para chapa fina de acero y acero inoxidable.	24	75	HSS	-	1,5-6	1,5-6	1-3	-	1-3	-	5	A-86561	0088381150910	7,40



B22	Para acero medio, inoxidable y plásticos duros, especialmente indicado para chapa fina.	24	50	HSS	-	1-6	1-3	1-3	-	1-3	T118A	5	A-85737	0088381149570	5,60
												2	B-01323	0088381117432	3,25



B24	Para acero medio fino, inoxidable y chapas de acero muy finas.	32	50	HSS	-	1-3	1-2	0,5-2	-	0,5-2	T118G	5	A-85759	0088381149594	5,40
-----	--	----	----	-----	---	-----	-----	-------	---	-------	-------	---	---------	---------------	------



B23	Acero medio, chapa de espesor medio, madera, chapa de madera decorativa y acero no ferroso.	14	50	HSS	3-35	3-35	2-6	-	2-6	2-6	T118B	5	A-85743	0088381149587	5,40
												2	B-01339	0088381117449	3,25



B27	Para cortes curvos en acero medio y no ferroso.	24	50	HSS	-	1-6	1-3	1-3	1-3	1-3	T218A	5	A-85787	0088381149631	6,80
-----	---	----	----	-----	---	-----	-----	-----	-----	-----	-------	---	---------	---------------	------

**Corte - Metal**

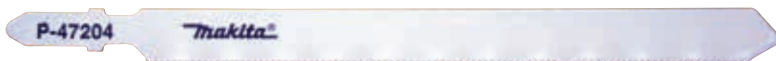

Tipo	Descripción	Dientes por pulgada	Longitud útil (mm)	Calidades material	Madera	Plástico	Aluminio	Metal inox	Metal no ferroso	Metal	Tipo Clase B	Uds. paquete	Código	EAN	P.V.P (€)
-	Para revestimiento de 80mm y materiales de sandwich. (hoja flexible)	25	105	BIM	-	-	-	-	-	1-3	T318AF	5	P-47204	0088381977630	10,60



-	Para tubería fina de materiales no ferrosos y revestimientos.	13	105	BIM	-	-	-	-	2,5-6	2,5-6	T318BF	5	P-47210	0088381977647	10,00
---	---	----	-----	-----	---	---	---	---	-------	-------	--------	---	---------	---------------	-------



-	Hoja flexible para chapa fina de acero medio e inoxidable con una prolongada vida útil.	21	55	BIM	-	-	-	1,2-2	-	1,2-2	T118AF	5	P-47226	0088381977654	8,30
---	---	----	----	-----	---	---	---	-------	---	-------	--------	---	---------	---------------	------

**Corte - Especial Inox**



Tipo	Descripción	Dientes por pulgada	Longitud útil (mm)	Calidades material	Madera	Plástico	Aluminio	Metal inox	Metal no ferroso	Metal	Tipo Clase B	Uds. paquete	Código	EAN	P.V.P (€)
-	Para acero medio e inoxidable	24	50	CV-HM	-	-	1,5-3	1,5-3	-	1,5-3	T118A-HM	1	P-05929	0088381944441	15,00



-	Hoja flexible para aceros medio e inoxidable, metal no ferroso con una prolongada vida útil	14	55	BIM	-	-	2-3	2-3	-	2-3	T118BF	5	P-47232	0088381977661	8,30
---	---	----	----	-----	---	---	-----	-----	---	-----	--------	---	---------	---------------	------

**Corte - Especial plásticos**



Tipo	Descripción	Dientes por pulgada	Longitud útil (mm)	Calidades material	Madera	Plástico	Aluminio	Metal inox	Metal no ferroso	Metal	Tipo Clase B	Uds. paquete	Código	EAN	P.V.P (€)
B21	Para trabajos de acabado en plásticos y aluminio.	12	75	HSS	-	3-60	1-10	-	-	-	T101A	5	A-85721	0088381149624	9,00

**Corte - Especial materiales blandos**



Tipo	Descripción	Dientes por pulgada	Longitud útil (mm)	Calidades material	Madera	Plástico	Aluminio	Metal inox	Metal no ferroso	Metal	Tipo Clase B	Uds. paquete	Código	EAN	P.V.P (€)
-	Ideal para cortar papel, corcho, goma y cuero.	-	75	HCS	-	-	-	-	-	-	T113A	5	A-80416	0088381136952	17,70

**Corte - Especial cerámica y fibra de vidrio**



Tipo	Descripción	Dientes por pulgada	Longitud útil (mm)	Calidades material	Madera	Plástico	Aluminio	Metal inox	Metal no ferroso	Metal	Tipo Clase B	Uds. paquete	Código	EAN	P.V.P (€)
-	Para cerámica de 5 - 15mm corte basto.	-	54	CV-HM	-	-	-	-	-	-	T130RI-FF	3	P-38788	0088381966696	15,50

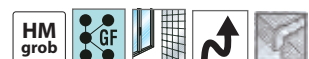

-	Para cerámica de grueso 5 - 20mm corte fino.	-	54	CV-HM	-	-	-	-	-	-	T150RI-FF	3	P-38794	0088381966702	15,50
---	--	---	----	-------	---	---	---	---	---	---	-----------	---	---------	---------------	-------



-	Para fibra de vidrio y plásticos reforzados. Dientes de carburo de tungsteno.	6	75	CV-HM	10-60	-	-	-	-	-	T141HM	3	B-06890	0088381289177	26,00
---	---	---	----	-------	-------	---	---	---	---	---	--------	---	---------	---------------	-------



-	Para fibra de vidrio y plásticos reforzados. Dientes de carburo de tungsteno.	6	105	CV-HM	10-95	-	-	-	-	-	T341HM	3	B-06909	0088381289184	35,00
---	---	---	-----	-------	-------	---	---	---	---	---	--------	---	---------	---------------	-------

**Corte - Especial panel sandwich**



Tipo	Descripción	Dientes por pulgada	Longitud útil (mm)	Calidades material	Madera	Plástico	Aluminio	Metal inox	Metal no ferroso	Metal	Tipo Clase B	Uds. paquete	Código	EAN	P.V.P (€)
-	Ideal para cortar papel, corcho, goma y cuero.	24	155	BIM	5-145	5-145	-	-	-	-	T718BF	5	P-49644	0088381980098	14,30



**Conjuntos de hojas a granel**

**Para corte rápido y limpio en madera y plásticos. Especial madera contrachapada**



Tipo	Descripción	Dientes por pulgada	Longitud útil (mm)	Calidades material	Madera	Plástico	Aluminio	Metal inox	Metal no ferroso	Metal	Tipo Clase B	Uds. paquete	Código	EAN	P.V.P (€)
B10	Conjunto de hojas a granel	9	75	HCS	3-65	3-65	-	-	-	-	T301CD	100	B-07674	0088381335294	106,00

**Para terminación de trabajos rápido. Corte limpio**



Tipo	Descripción	Dientes por pulgada	Longitud útil (mm)	Calidades material	Madera	Plástico	Aluminio	Metal inox	Metal no ferroso	Metal	Tipo Clase B	Uds. paquete	Código	EAN	P.V.P (€)
B11	Conjunto de hojas a granel	9	75	HCS	3-60	3-60	-	-	-	-	T101B	100	B-07680	0088381335300	111,00

**Para corte rápido en madera y plásticos. Corte rápido y basto**



Tipo	Descripción	Dientes por pulgada	Longitud útil (mm)	Calidades material	Madera	Plástico	Aluminio	Metal inox	Metal no ferroso	Metal	Tipo Clase B	Uds. paquete	Código	EAN	P.V.P (€)
B16	Conjunto de hojas a granel	6	75	HCS	5-65	5-65	-	-	-	-	T144D	100	B-07711	0088381335331	94,00

**Para acero medio, inoxidable y plásticos duros. Indicado para chapa fina**



Tipo	Descripción	Dientes por pulgada	Longitud útil (mm)	Calidades material	Madera	Plástico	Aluminio	Metal inox	Metal no ferroso	Metal	Tipo Clase B	Uds. paquete	Código	EAN	P.V.P (€)
B22	Conjunto de hojas a granel	24	50	HSS	-	1-6	1-3	1-3	-	1-3	T118A	100	B-07733	0088381335355	90,00

**Para cortes en madera y plásticos**



Tipo	Descripción	Dientes por pulgada	Longitud útil (mm)	Calidades material	Madera	Plástico	Aluminio	Metal inox	Metal no ferroso	Metal	Tipo Clase B	Uds. paquete	Código	EAN	P.V.P (€)
B13	Conjunto de hojas a granel	8	80	HCS	4-65	4-65	-	-	-	-	T111C	100	B-07705	0088381335324	73,00



### Trípodes



Tipo	Descripción	Rosca	Unds.	Código	EAN	P.V.P. (€)
1	Tripode aluminio 1,65M máx.	5/8"	1	P-81088	88381449564	134,00
2	Tripode aluminio 2,70M máx.	5/8"	1	P-81315	88381451291	345,00
3	Tripode 1800 para SK209	1/4"	1	TK0LM4001F	88381442374	151,00
4	Tripode 2900 para SK209	1/4"	1	TK0LM5030F	88381442381	218,00
5	Tripode aluminio 1,15m máx SK700D	1/4"	1	LE00874658	088381539876	122,00

### Cables USB



Permite usar una batería LXT de 18V cuando se usa con el adaptador para USB ADP05 (se vende por separado).

Descripción	Modelo	Unds.	Código	EAN	P.V.P. (€)
Cable USB	SK209	1	199010-3	0088381519663	13,80
Cable usb	SK105 SK106	1	199178-5	0088381528238	11,00



### Adaptador tipo batería para SK700



Descripción	Unds.	Código	EAN	P.V.P. (€)
Adaptador ADP09 para SK700	1	CP00000001	0088381548571	33,00

### Escala de aluminio



Longitud	Unds.	Código	EAN	P.V.P. (€)
1,2 - 4,0 m	1	P-81309	0088381451178	77,00

### Tarjetas magnéticas

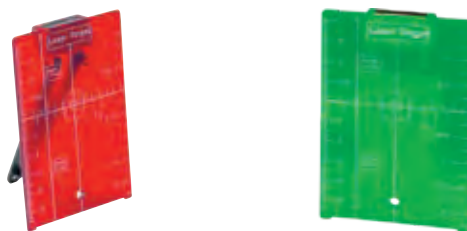

Descripción	Unds.	Código	EAN	P.V.P. (€)
Tarjeta magnética roja SK102 / SK103	1	LE00785638	3240890328830	17,90
Tarjeta magnética roja SK105DZ / SK106DZ		LE00758831	8720023001038	18,50
Tarjeta magnética verde	1	LE00823195	0088381851923	25,00

### Bolsas de transporte



LE00864505

Descripción	Modelo	Unds.	Código	EAN	P.V.P. (€)
Bolsa funda	SK104Z SK103PZ	1	LE00822220	-	31,00
Bolsa funda	SK105D SK105GD SK106D SK106GD	1	LE00864505	0088381549547	39,00
Bolsa funda	SK700D SK700GD	1	LE00929103	88381790079	46,00

### Gafas para mejorar la visión del láser



Descripción	Unds.	Código	EAN	P.V.P. (€)
Gafas para láser Rojo (1)	1	LE00834534	0197050355737	20,00
Gafas para láser Verde (2)	1	LE00772796	-	26,00
Gafas para láser Verde (1)	1	TK02100200	0088381795593	20,00

**Linterna de área 5.500Lm - ML010G**

- 3 ajustes de brillo: 5.500 / 3.000 / 1.500 Lm.
- 3 niveles de iluminancia: 550 / 280 / 130Lx. \*
- Bloqueo de la tapa de la batería para proteger la batería del robo.
- Capaz de conectar hasta 8 unidades ML010 en serie.
- Alojamiento para dos baterías LXT.
- Certificación IP54 de resistencia al polvo y al agua. \*\*
- Tiempo de iluminación: 6,5H en modo 360 con BL4040x2.
- AC/DC.



\*A 1m de distancia. \*\* Sólo con alimentación DC.

Dimensiones	Unds.	Código	EAN	P.V.P (€)
490 x 490 x 814mm	1	ML010G	-	950,00

**Trípode regulable 3.000 Lm - DML814**

- 3 ajustes de brillo: 3.000 / 1.700 / 900 Lm.
- 3 niveles de iluminancia: 1.250 / 750 / 400Lx. \*
- 3 cabezales individuales giratorios.
- Luz LED blanca, ideal para trabajo.
- Los cierres tienen con un tornillo de ajuste.
- Tapa de batería con candado.
- Plegable en un tamaño compacto para un almacenamiento y transporte sencillo.
- Tiempo de iluminación: 3H en brillo alto con BL1850B.

**Primer trípode de iluminación Makita**

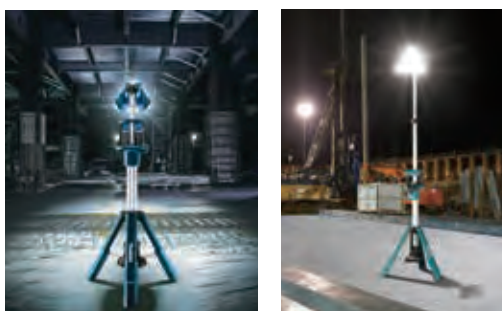

Dimensiones	Unds.	Código	EAN	P.V.P (€)
573 x 658 x 2.240mm	1	DML814	0088381728614	452,00

**Nuevos focos de iluminación**



**Foco de iluminación 10.000Lm - ML009GX**

- 3 ajustes de brillo: 10.000 / 4.000 / 2.000 Lm.
- 3 niveles de iluminancia: 4.300 / 1.900 / 1.000 Lx. \*
- Función de memoria en la configuración de brillo.
- Clasificación IP65 para resistencia al agua.
- Tiempo de iluminación: 2,4H en brillo alto con BL4040x2.



Dimensiones	Unds.	Código	EAN	P.V.P (€)
248 x 386 x 305 mm	1	ML009GX	-	555,00



Trípode ML009GX	1	GM00002378	-	190,00
-----------------	---	------------	---	--------

**Foco de iluminación 1.100Lm - ML005GX**

- 3 ajustes de brillo: 3.600 / 1.800 / 900 Lm.
- 3 niveles de iluminancia: 2.100 / 1.000 / 500 Lx. \*
- Función de memoria en la configuración de brillo.
- Clasificación IP65 para resistencia al agua.
- Tiempo de iluminación: 3,5H en brillo alto con BL4040.



Dimensiones	Unds.	Código	EAN	P.V.P (€)
248 x 309 x 296 mm	1	ML005GX	-	330,00



Difusor luz DML811	1	GM00002358	-	12,50
--------------------	---	------------	---	-------



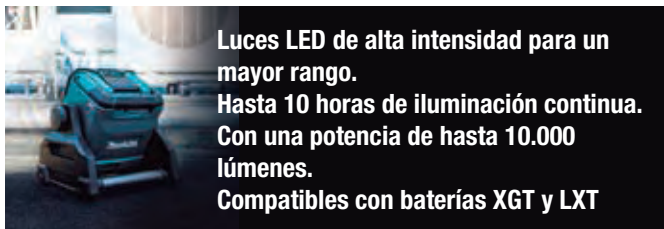

Luces LED de alta intensidad para un mayor rango.  
Hasta 10 horas de iluminación continua.  
Con una potencia de hasta 10.000 lúmenes.  
Compatibles con baterías XGT y LXT

**Foco de iluminación 1.100Lm - ML003G**

- 2 ajustes de brillo: 1.100 / 450 Lm.
- 2 niveles de iluminancia: 500 / 200 Lx. \*
- Función de memoria en la configuración de brillo.
- Clasificación IP65 para resistencia al agua.
- Tiempo de iluminación: 10H en brillo alto con BL4040.



Dimensiones	Unds.	Código	EAN	P.V.P (€)
249 x 298 x 280 mm	1	ML003GZ	0088381746632	231,00

**Foco de iluminación 10.000Lm - DEADML809**

- 3 ajustes de brillo: 10.000 / 4.000 / 2.000 Lm.
- 3 niveles de iluminancia: 3.800 / 1.500 / 800 Lx. \*
- Clasificación IP65 para resistencia al agua.
- Tiempo de iluminación: 1,4H en modo alto con BL1850x2.



Dimensiones	Unds.	Código	EAN	P.V.P (€)
249 x 370 x 370mm	1	DEADML809	0088381888264	474,00



Descripción	Unds.	Código	EAN	P.V.P (€)
Difusor luz DML809	1	GM00002286	-	21,00
Tripode de altura ajustable 1,3 m a 2,0 m.	1	GM00002073	0088381548830	228,00

**Foco de iluminación 750Lm - DEADML805**

- 2 ajustes de brillo: 750 / 450 Lm.
- 2 niveles de iluminancia: 300 / 200 Lx. \*
- Muy ligero. Asa a modo de gancho.
- Tiempo de iluminación: 8,5H modo alto con BL1850.



Dimensiones	Unds.	Código	EAN	P.V.P (€)
214 x 261 x 328 mm	1	DEADML805	0088381699303	186,00



Descripción	Unds.	Código	EAN	P.V.P (€)
Sujección gancho	1	GM00001396	0088381455688	22,00
Tripode	1	GM00002283	0088381579476	72,00
Difusor luz DML805	1	GM00002377	-	19,00
Lámina antideslumbrante	1	GM00002376	-	12,00

**Foco de iluminación 3.000Lm - DML811**

- 3 ajustes de brillo: 3.000 / 1.500 / 750 Lm.
- 3 niveles de iluminancia: 1.800 / 800 / 350 Lx. \*
- Clasificación IP65 para resistencia al agua.
- Tiempo de iluminación: 3H en modo alto con BL1860B.
- Ajuste de ángulo de luz: de -30° a 210°.



Dimensiones	Unds.	Código	EAN	P.V.P (€)
249 x 302 x 271 mm	1	DML811	-	315,00



Descripción	Unds.	Código	EAN	P.V.P (€)
Difusor luz DML811	1	GM00002287	-	14,30

**Foco de mano 1.250Lm - ML007G**

- 3 ajustes de brillo: 600Lm proyector, 1.000Lm lupa y 1.250Lm mixto.
- 3 niveles de iluminancia: 82.000Lx proyector, 520Lx lupa y 60.000Lx mixto. \*
- 4 modos: proyector, fijo, mixto y estroboscópico.
- Distancia de haz de hasta 640m en modo fijo.
- La cabeza de la linterna gira 90°.
- Tiempo de iluminación: 10H en modo proyector con BL4040.



Dimensiones	Unds.	Código	EAN	P.V.P (€)
330 x 120 x 133 mm	1	ML007G	0088381762342	182,00

**Foco de mano 1.250Lm - DML812**

- 3 ajustes de brillo: 600Lm proyector, 1.000Lm lupa y 1.250Lm mixto.
- 3 niveles de iluminancia: 71.000Lx proyector, 500Lx lupa y 51.000Lx mixto. \*
- 4 modos: proyector, fijo, mixto y estroboscópico.
- Distancia de haz de hasta 640m en modo fijo.
- La cabeza de la linterna gira 90°.
- Tiempo de iluminación: 10H en modo proyector con BL1860B.



Dimensiones	Unds.	Código	EAN	P.V.P (€)
313 x 119 x 115 mm	1	DML812	-	159,00

**Linterna de mano - DEBDML186**

- 6 luces LED. 1 nivel de iluminancia: 500Lx. \*
- Tiempo de iluminación: 50H con BL1830B.



Dimensiones	Unds.	Código	EAN	P.V.P (€)
151 x 81 x 61mm	1	DEBDML186	-	26,00



**Linterna 190Lm - DEADML808**

- 1 ajuste de brillo: 190Lm.
- Nivel de iluminancia: de 170 – 4.500Lx. \*
- Cabezal pivotante de 12 posiciones de 0° a 170°.
- Con función de zoom que ajusta el rango de iluminación.
- Tiempo de iluminación: 32H con BL1860B.



Dimensiones	Unds.	Código	EAN	P.V.P (€)
297 x 79 x 119mm	1	DEBDML808	-	66,00

**Linterna 190Lm - DEAML106**

- 1 ajuste de brillo: 190Lm.
- Nivel de iluminancia: 170-4.500Lx. \*
- Función zoom que ajusta el rango de iluminación.
- Accesorio magnético opcional.
- Reflector multifacético que se ilumina uniformemente.
- Tiempo de iluminación: 12H con BL1041B.



Dimensiones	Unds.	Código	EAN	P.V.P (€)
290 x 66 x 93mm	1	DEAML106	0088381853125	66,00





# Makita®

Catálogo de accesorios  
**CONSTRUCCIÓN**  
2025



C/ Juan de la Cierva, 7-15  
28823 Coslada (Madrid) España  
Telf: (34) 91 671 12 62 Fax: (34) 91 671 82 93

VIDEO CORPORATIVO



[www.makita.es](http://www.makita.es)